

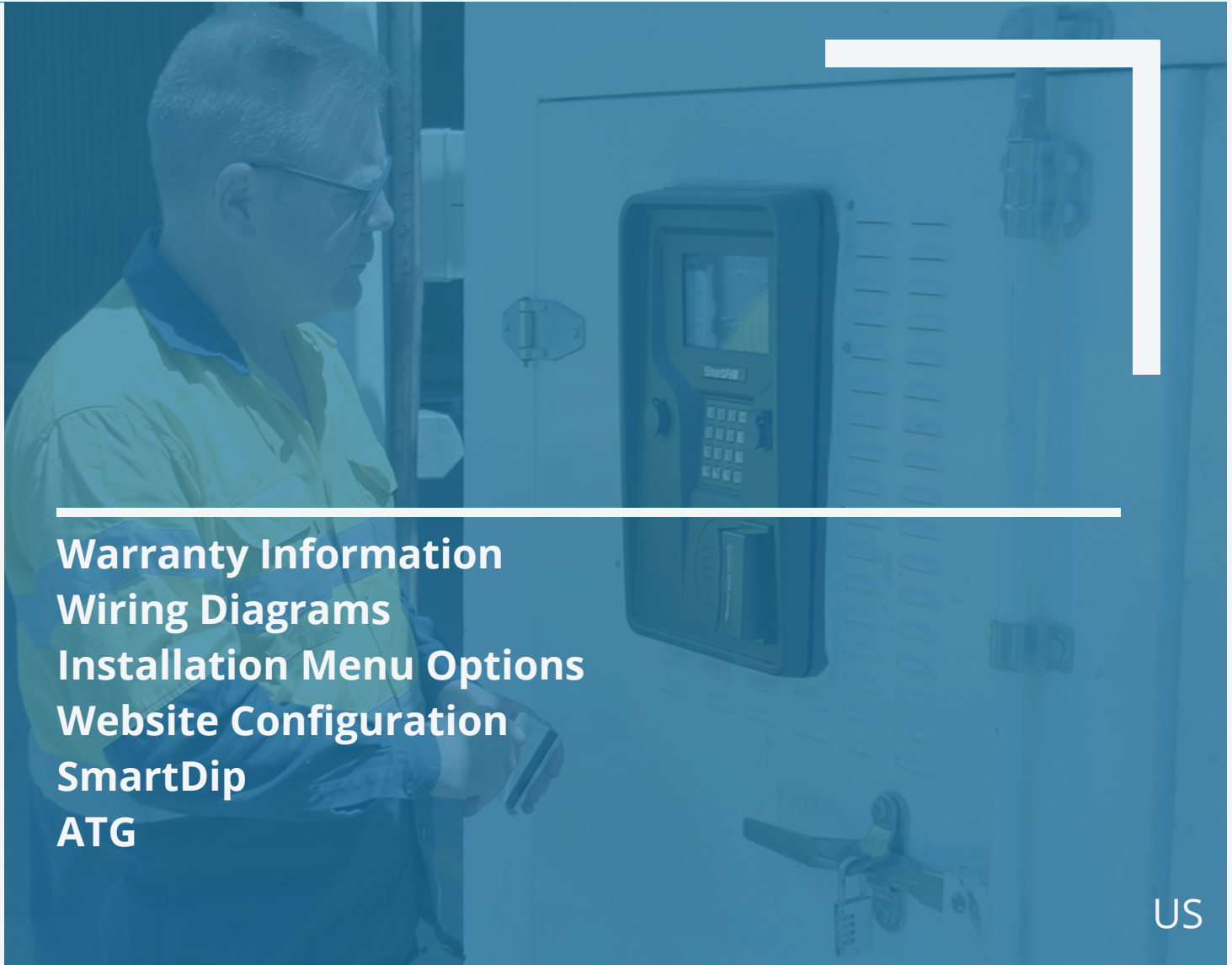

SmartFill Gen 3 Installer Manual

A photograph of a technician in a yellow safety vest and glasses, looking at a SmartFill Gen 3 device mounted on a metal cabinet. The device has a screen and a keypad. The image is overlaid with a blue tint and a white L-shaped graphic element in the top right corner.

Warranty Information
Wiring Diagrams
Installation Menu Options
Website Configuration
SmartDip
ATG

Revision	Date	Detail
1.0	09 May 2022	US Manual First Release
1.1	07 Dec 2022	Cover Update
1.2	06 Jun 2023	Various Updates

Contents

1	General Information	9
1.1	Introduction	9
1.2	Overview	9
1.3	Terminology	9
1.4	Safety Warnings	10
1.4.1	Installing Company / Personnel Requirements	11
1.4.2	Power Conditioners/Voltage Regulators	11
1.4.3	Backup Generators	11
1.5	Ratings	11
1.6	Certifications/Approvals	12
1.7	Warranty Information	13
1.7.1	Warranty	13
1.7.2	Warranty Claim Procedure	13
1.7.3	General Exclusions and Limitations of the Warranty	14
1.8	Recommended Tools for Installers	15
1.9	Pre-Installation Checks	15
1.10	Safety Related Inspections and Preventative Maintenance	15
1.11	Cleaning Instructions	15
1.12	Support	15
2	SmartFill GEN 3 Installation and Configuration	16
2.1	Mounting the SmartFill GEN 3	16
2.1.1	Choosing the Location	16
2.1.2	Mount the SmartFill GEN 3 to the pump / flowmeter	16
2.1.3	Mounting Dimensions	17
2.1.4	Seals	17
2.2	Power Wiring	18
2.2.1	General Warnings	18
2.2.2	Conduit Requirements	18
2.2.2.1	Conduit Size	18
2.2.2.2	Conduit Fill Capacity	18
2.2.2.3	Conduit Applications	19
2.2.3	Emergency Stop Switch Recommendations	19
2.2.4	Backup Generators	19
2.2.5	Bypass Operation	20
2.3	Termination of a Transaction	20
2.3.1	Nozzle Switch	20
2.3.2	DC Power Out	20
2.4	AC System Wiring	21
2.4.1	Single AC Wiring	21
2.4.2	Dual AC Wiring Two Flowmeters	22
2.4.3	Dual AC Hoses with One Flowmeter	23
2.4.4	Wayne CL	24
2.5	DC Wiring	25
2.5.1	Single Hose DC Switched	25
2.5.2	DC Switched Dual Hoses with Two Flowmeters	26
2.5.3	DC Switched Dual Pumps with Single Flowmeter	27
2.5.4	DC Systems Delay Power Off Option	28
2.5.4.1	Auto Power Off	28
2.5.4.2	Auto Power Off Wiring	28
2.6	Pulser Installation	29
2.6.1	Pulse input theory	29
2.6.2	Pulser Application Chart	29
2.6.3	Connections to a Pulser Module on Flowmeter	30

2.6.4	Gasboy® 9800A or 2600A Pump Interface Kits Pulse-out I/F Board (M06587A001) Jumper Settings	31
2.6.5	OPW Model 800-F Pulser	33
2.6.6	Bennett Pulse Output wiring	34
2.7	Calibrating and Testing the Unit	35
2.7.1	Adding a Test Key	35
2.7.2	Calibrate by setting the K-Factor	36
2.7.3	Setting the K-Factor using Auto Calibrate	36
2.7.4	Initial Suggested K Factors	37
2.8	Gilbarco Comms SmartFill GEN 3	38
2.8.1	Data Cabling	38
2.8.2	Wiring Diagram	38
2.8.3	Gilbarco Communications	39
2.8.4	5 / 6 Digit purpose and setup	39
2.8.4.1	5 / 6 digit Liters setup procedure	39
2.8.5	Gilbarco comms test procedure	39
2.8.5.1	Comms loop current check	40
2.8.5.2	Comms loop voltage drop check	41
2.8.5.3	Troubleshooting	41
2.9	Inflow Module Wiring	42
2.10	Communications Setup	43
2.10.1	3G/4G Setup	43
2.10.1.1	Details for the 3G/4G SIM	43
2.10.2	Wi-Fi Setup	45
2.10.3	Ethernet	47
2.10.3.1	Enable Static IP Addressing:	47
2.11	MicroSD Card	48
2.12	Using the System to Get Fuel	49
2.13	Short Cut keys	49
2.14	SmartFill Gen 3 Installation Menu	49
2.14.1	Vehicles	50
2.14.2	Plant	51
2.14.3	Drivers	51
2.14.4	Transactions	51
2.14.5	Unit	52
2.14.6	Time & Date	53
2.14.7	Tanks	54
2.14.7.1	Tanks	54
2.14.8	Pumps/Flowmeters	55
2.14.9	More	57
2.14.10	Power	57
2.14.11	Network	58
2.14.11.1	Ethernet	58
2.14.11.2	Wi-Fi	59
2.14.11.3	Cellular	59
2.14.12	Volumetric Units	59
2.14.13	Printer	60
2.14.13.1	Printer Communications Settings	61
2.14.14	System Information	61
3	Configuring and Using Website Page	62
3.0.1	Creating Your Website and Adding Your First Unit	62
3.0.2	Logging In Once the Website is Created	63
3.0.3	Dashboards	63
3.0.4	Transactions Page	64
3.0.4.1	Transactions	64
3.0.4.2	Transactions - Edit Columns	65
3.0.5	Reports	65
3.0.5.1	New Report	65
3.0.5.2	Configure Reports	66
3.0.6	Accounts	66
3.0.6.1	Accounts - Add New Account	66
3.0.6.2	Accounts - View	66
3.0.6.3	Accounts - Delete	66
3.0.7	Vehicles	67
3.0.7.1	Add Vehicle	68
3.0.7.2	View	68

3.0.7.3	Edit Columns	68
3.0.7.4	Configure Vehicles	68
3.0.8	Drivers	70
3.0.8.1	Add Driver	70
3.0.8.2	Drivers - View	70
3.0.8.3	Drivers - Edit Columns	70
3.0.8.4	Configure Drivers	71
3.0.9	Tanks	72
3.0.9.1	Tanks Page	72
3.0.9.2	Tank Level - Columns	73
3.0.9.3	Tanks - Dips	73
3.0.9.4	Tanks - Transfers	73
3.0.9.5	Tanks - Deliveries	73
3.0.9.6	Tanks - Fuel Suppliers	73
3.0.9.7	Configure Tanks	73
3.0.10	Custom User Data	75
3.0.10.1	Configure User Data	75
3.0.11	Jobs	76
3.0.11.1	Add Job	76
3.0.11.2	Configure Jobs	76
3.0.12	Units	77
3.0.12.1	Alerts	77
3.0.12.2	Software Update	77
3.0.12.3	Import (From Unit to Website)	77
3.0.12.4	Export (From Website to Unit)	77
3.0.12.5	Add New Unit	77
3.0.12.6	Unit - Configure	78
3.0.13	Admin	83
3.0.13.1	Admin - ISO/Access Registration	84
3.0.13.2	View/Edit Users	85
3.0.13.3	Invite New User	85
3.0.13.4	My Profile - Change Password	85
4	Automatic Tank Gauging Interface	87
4.1	Introduction	87
4.2	Operation	87
4.3	ATG Setup	87
4.3.1	RS232 Serial Communication – RS232 requires a three (3) wire interface. The three (3) wires are Receive, Transmit, Common/Ground. Interconnect the two systems in accordance with Table 4.1 and Figure 4.1.	87
4.3.2	RS485 Serial Communication – RS485 requires a two (2) wire interface. The two (2) wires are Plus and Minus. Interconnect the two systems in accordance with Table 4.3 and Figure 4.2	88
4.4	SmartFill ATG module to Pneumercator TMS Series panels via RS 232	89
4.5	SmartFill Set Up	90
5	SmartDip Installation and Configuration	91
5.1	Overview	91
5.2	Installation	91
5.2.1	Tank sensor installation to tank.	92
5.2.2	Tank sensor electrical connections.	92
5.3	Set Up of SmartDip	93
5.3.1	Tanks	93
5.3.2	Tank Gauging Settings	93
5.3.2.1	Tank Configuration	93
5.3.2.2	Tank 1..8 Configuration	94
5.3.2.3	Notifications	95
5.3.2.4	Tank Levels	95
5.4	Troubleshooting	95
5.4.1	Tank level not changing on the website	95
5.4.2	Tank level incorrect	95
5.4.3	No tank level showing	95
5.4.4	Tank level at 100%	95
5.4.5	The SmartDip module.	95
5.4.5.1	Open Circuit	95
5.4.5.2	Short Circuit (current > 27.6mA)	95
5.4.5.3	For testing the module there should be a 1K resistor fitted to input 4.	95

6	Troubleshooting at the SmartFill GEN 3 unit.	96
6.0.1	Key Problems	96
6.0.1.1	Require more vehicle keys?	96
6.0.1.2	SmartFill GEN 3 does nothing when a key is presented.	96
6.0.1.3	Keys shows as 'INVALID'.	96
6.0.1.4	Lost vehicle keys.	96
6.0.1.5	Lost door lock key.	97
6.0.2	Not asking for additional data?	97
6.0.3	Pump / dispenser problems.	97
6.0.3.1	Pump stops after a short period.	97
6.0.3.2	SmartFill GEN 3 is not recording Liters accurately.	97
A	SmartFill GEN 3 Terminology.	98
B	Operating Principles.	99
B.0.1	Relay control.	99
B.0.1.1	Relay.	99
B.0.2	Communication access control.	99

List of Figures

1.1	Boundaries for Hazardous Locations	12
2.1	SF3 Enclosure mounting dimensions.	17
2.2	Sample Site Layout	19
2.3	Nozzle Switch Wiring for AC and DC Pump Modules	20
2.4	Wiring for Single Hose with Mains Switching	21
2.5	Wiring for Dual Hoses with Mains Switching and Two Flowmeters	22
2.6	Wiring for Dual Hoses with AC Switching and One Flowmeter	23
2.7	Wiring for Wayne CL Protocol	24
2.8	Wiring for Single Hose with DC Switching	25
2.9	Wiring for Dual Hoses with DC Switching and Two Flowmeters	26
2.10	Wiring for Dual Hoses with DC Switching and One Flowmeter	27
2.11	Connection to Flowmeters: Reed and Hall Effect Sensors	30
2.12	Gasboy Interface Kits	31
2.13	Dual Pulse Input	31
2.14	Dual Pulse from Single Pulser	32
2.15	Model 800 Pulser	33
2.16	Bennett Pulser Wiring	34
2.17	Installation Menu	35
2.18	SmartFill GEN 3 Gilbarco Wiring diagram.	38
2.19	Multimeter set up to measure DC milliamp in the comms loop.	40
2.20	Multimeter set up to measure voltage drop over the comms loop.	41
2.21	Wiring for InFlow Module	42
2.22	Installing SIM	43
2.23	Enter SSID Screen	45
2.24	Static Address Menu	47
2.25	MicroSD Card Slot on the Door Board	48
2.26	Enter Admin or Installer PIN Screen	49
2.27	Installation Menu	50
2.28	Vehicles Menu	50
2.29	Plant Menu	51
2.30	Drivers Menu	51
2.31	Transactions Menu	52
2.32	Selecting Preset Type	52
2.33	Unit Menu	53
2.34	Clear Settings Menu	53
2.35	Time & Date Menu	54
2.36	Tank Gauging Settings Menu	54
2.37	Tank 1	55
2.38	// Calibration Menu	55
2.39	Pumps/Flowmeters Menu	56
2.40	Pulser Settings Menu	56
2.41	Bulk Delivery Menu	57
2.42	More Settings Page	57
2.43	Power Settings	58
2.44	Ethernet Network Settings	58
2.45	Wi-Fi Network Settings	59
2.46	Cellular Network Settings	59
2.47	Volumetric Units Menu	60
2.48	Printer Menu	60
2.49	Printer Comms Menu	61
2.50	System Information Menu	61
3.1	Initial Account Activation Page	62
3.2	Dashboard Page	63

- 3.3 Website Transaction Page 64
- 3.4 Configuring the Transactions Page 65
- 3.5 Reports Page 65
- 3.6 Accounts Page 66
- 3.7 Vehicles Page 67
- 3.8 Time of Day Setup 68
- 3.9 Drivers Page 70
- 3.10 Add Driver Page 70
- 3.11 Tanks Page 72
- 3.12 Add SmartTank Page 74
- 3.13 Pump to Tank Mapping on the Website 74
- 3.14 User Defined Data Page 75
- 3.15 Jobs Page 76
- 3.16 SmartFill Units Page 77
- 3.17 Configuration - General 78
- 3.18 Configuration - Pumps 79
- 3.19 Configuration - Admin 80
- 3.20 Configuration - Tank Gauges 81
- 3.21 Configuration - Admin 82
- 3.22 Admin 83
- 3.23 Admin ISO/Access Registration 84
- 3.24 Add ISO/Access Pair 84
- 3.25 Admin View/Edit Users 85
- 3.26 Admin Add User 85
- 3.27 Admin Change Password 86

- 4.1 RS232 Wiring 88
- 4.2 RS485 Wiring 88

- 5.1 New Tank Pressure Sensor Installation 92
- 5.2 Tank Pressure Sensor Connections 92
- 5.3 Installer menu with SmartDip fitted 93
- 5.4 Tank Gauging Settings Menu 93
- 5.5 Tank x Configuration Menu 94

Chapter 1

General Information

1.1 Introduction.

This manual is designed to step through the installation of a SmartFill GEN 3 system, in the order of events that take place during a normal installation. Please contact the manufacturer should you have suggestions, or error corrections.

There are icons used in this manual, which are designed to draw your attention to a particular area of importance. There are only 2 used, and their meanings are as follows.

WARNING



WARNING. This icon indicates that the relevant information is warning you of a potential hazard, or mishap event that may occur if you do not read and follow the advice given. It is extremely important that you read and fully understand information following a Warning Icon.



TIP. This icon indicates that the information is a Tip to assist you, a suggestion or a shortcut to a better method.

1.2 Overview

SmartFill GEN 3 is a state of the art fuel management system specifically designed to work in the most demanding of environments. It is housed in a rugged Automotive Grade Nylon Resin enclosure that is built to survive harsh environments and its modular design ensures ease of installation, upgrade and repair.

Users access fuel by using either keys or entering identification information via the keypad. Transactions always include the vehicle identification, the time and date, the quantity of fuel dispensed, the pump from which the fuel was taken and if enabled, the driver, the odometer/ hours of the vehicle or plant.

All data is stored in the unit and, if connected to the Internet, automatically sent to a secure website: www.fmtdata.com. The unit can be connected to the website using an Ethernet connection that has a connection to the Internet, a Wi-Fi connection or a 3G/4G connection.

The unit can be configured locally using the keypad and on-screen menus or via the website.

1.3 Terminology

Term	Meaning
Key	iButton or NFC card/Fob used to identify a driver or vehicle
Module	A plug in module that is used in the unit e.g pump module
AC	Alternating Current - normally 110VAC/Mains power
DC	Direct Current - either 12V or 24V DC

1.4 Safety Warnings

WARNING



- **HIGH VOLTAGE WARNING** - Some SmartFill GEN 3 systems involve / require hazardous electrical voltages to be present. Electrical installation, testing, maintenance or repairs **MUST** be carried out by a suitably licensed electrician.
- To help prevent electrical shock, connect the SmartFill GEN 3 into properly grounded sources.
- To help prevent possible damage to the SmartFill GEN 3 and or other interfacing equipment, wait 5 seconds after turning off all interfacing equipment before disconnecting interconnecting cables.
- To help protect your SmartFill GEN 3 from sudden, transient electrical increases, your SmartFill GEN 3 is equipped with surge protection. All equipment interfacing your SmartFill GEN 3 needs to use a surge suppressor, line conditioner, or un-interruptable power supply (UPS).
- Be sure nothing rests on your SmartFill GEN 3 cables and that the cables are not located where they can be stepped on or tripped over.
- Do not push objects into the openings of your SmartFill GEN 3. Doing so can cause fire or electrical shock by shorting-out internal components.
- In addition, take note of these safety guidelines when appropriate:
 - When you disconnect a cable, pull on its connector or its strain-relief loop, not on the cable itself. Some cables have a connector with locking tabs. To disconnect this type of cable, press in the locking tabs before disconnecting the cable. As you pull connectors apart, keep them evenly aligned to prevent bending connector pins. Also, before you connect a cable, make sure the two connectors are correctly oriented and aligned.
 - Hold components by their edges or by their metal mounting brackets.
- Safety concerns about the system should be immediately reported to your SmartFill GEN 3 supplier and the manufacturer.
- The system must be put out of order, suitably danger or out of service tagged, and must not be used if you have safety concerns.
- The SmartFill GEN 3 manufacturer's bear no responsibility / liability for work carried out by unqualified service personnel.
- All wiring **MUST** be in accordance with the relevant local / state / national regulations as required.
- Special precautions must be taken to ensure that the wiring and location of SmartFill GEN 3 systems is in accordance with the relevant regulations and authorities for that particular location.
- Special attention must be paid to locating equipment in possibly hazardous areas.
- The manufacturer can not provide advice or specification for correct wiring or hazardous area regulations, and in no way implies its suitability for use in a given area, this information **MUST** be sought by the installer, from the relevant authorities.
- SmartFill GEN 3 enclosures are not rated for use in hazardous areas, and as such the SmartFill GEN 3 must only be operated in a non-hazardous area.
- References: The following references, as a minimum, and as they apply to the installation, must be familiar to the technician performing the SmartFill GEN 3 installation:
 - NFPA Handbook 30, Flammable and Combustible Liquids Code, provides requirements for the safe storage and handling of flammable and combustible liquids.
 - NFPA Handbook 30A, Code for Motor Fuel Dispensing Facilities and Repair Garages, provides safeguards for dispensing liquid and gaseous motor fuels into the fuel tanks of automotive vehicles and marine craft.
 - NFPA Handbook 70, National Electrical Code (NEC), contains guidelines for the installation and operation of electrical equipment. Chapter 5 specifically addresses the installation of electrical equipment in hazardous locations.
 - NFPA Handbook 407, Standard for Aircraft Fuel Servicing, provides minimum fire safety requirements for procedures, equipment and installations during ground fuel servicing of aircraft using liquid petroleum fuels. Knowledge of this reference is necessary when performing an installation in support of aircraft fuel servicing.

1.4.1 Installing Company / Personnel Requirements.

- The quality of installation has a lasting effect on the performance of the equipment, and the value the SmartFill GEN 3 end user receives from the system. We cannot stress enough the importance of safe and high standard installation and commissioning practice's. Thorough initial basic training of the client is also crucial to the client getting best value from the equipment. Obviously, sufficient initial training also reduces the number of support calls that the installer receives.
- The installing company is responsible for ensuring that installation staff are competent, they are suitably qualified, and that work is performed in a safe manner, to a high standard.

1.4.2 Power Conditioners/Voltage Regulators

In locales where power sources fluctuate significantly and over voltages or brownouts occur, power conditioners or voltage regulators may be installed between the SmartFill GEN 3 and its power source for protection against high or low power inputs. These devices condition or regulate power to a constant or maximum output. Power conditioners maintain a constant power input when voltage may otherwise fluctuate between highs and lows which are not suitable for SmartFill GEN 3. Voltage regulators protect SmartFill GEN 3 from high voltage inputs similar to what may occur when an unregulated generator is initially turned on. Power conditioners are more complex and substantially more expensive to purchase.

1.4.3 Backup Generators

Some facilities are equipped with backup generators to supply AC power when the regular power supply goes down. During start-up of the backup generator the initial power surge may be extremely high until all connected equipment is restored to operation. This power surge has the same potential for damage to the SmartFill GEN 3 equipment as a lightning strike. Ensure the installed equipment is protected (regulated) from current surges during start-up of the backup power source. If possible, turn off the SmartFill GEN 3 power until non-regulated generator power stabilizes.

1.5 Ratings

	AC	DC
Operating Voltage	90 - 250 VAC	10 - 36 VDC
Operating Current	0.38A - 0.15A	2A - 0.6A
Pulser	15V @ 2.5mA	15V @ 2.5mA
Nozzle Switch	3.3V @ 0.2mA	3.3V @ 0.2mA
Fuse Rating	1A	2A
Maximum Switching	250VAC @ 10A	24VDC @ 5A
Delay Power Switch	N/A	36V @ 2A

1.6 Certifications/Approvals

Figure 1 illustrates the boundaries of a hazardous location which dispenses flammable liquids such as gasoline and E85.

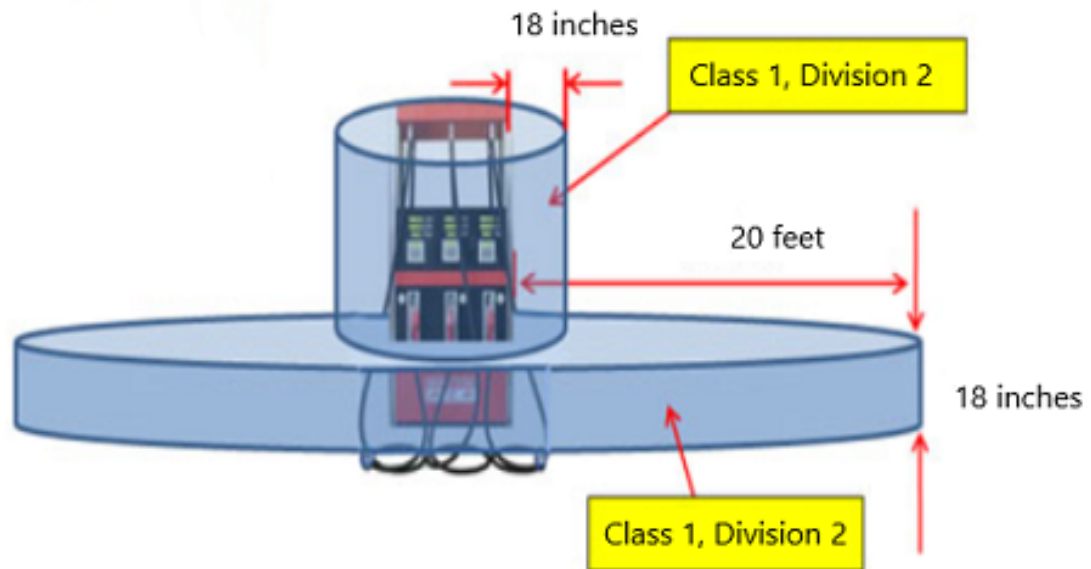

125

Figure 1.1: Boundaries for Hazardous Locations

The boundary area around a compressed natural gas (CNG) dispenser is different. It extends 5 feet from, and above, the dispenser. An electrical device installed within these boundaries must be intrinsically safe or must be enclosed within an explosion-proof enclosure. Intrinsically safe devices are generally limited to very low voltage and low current devices, such as that portion of a pulser before the barrier. Examples of explosion-proof enclosures are rigid metal conduit, and junction boxes and conduit fittings approved for use in hazardous locations. If the electrical device is not intrinsically safe, or is not explosion-proof, then it must be installed outside the hazardous area.

1.7 Warranty Information

1.7.1 Warranty

1. FMT shall provide to the Customer a warranty for all Goods against defects in materials and workmanship for a two year period (the Warranty Period) commencing on the sale date to the Customer (the Warranty Commencement Date) of the relevant Goods.
2. The Product Warranty only applies to the Customer who originally purchased the Goods. It is personal and may not be assigned or transferred without the prior written consent of FMT.
3. Subject to Clause 1.7.2, FMT (at its option) will replace or repair for the Customer, free of charge, part or parts, found upon examination by FMT, to be eligible for this Product Warranty. If any Goods or part is replaced or repaired under this Product Warranty, that Goods or part will carry the remainder of the Product Warranty from the Warranty Commencement Date.
4. The Product Warranty is in addition to any consumer guarantees existing available to the Customer at law and the Product Warranty does not exclude such consumer guarantees.
5. All enquiries regarding the Product Warranty may be directed to FMT on 1 800 569 8704.
6. All warranty requests will need to be submitted via email to support.us@fmtweb.com which will generate a unique RMA number, an RMA form will need to be completed with the details of the request.

1.7.2 Warranty Claim Procedure

1. In order to make a claim under the Product Warranty, the Customer must notify FMT in writing of any defect in the Goods discovered during the Warranty Period as soon as the Customer becomes aware of the alleged defect specifying in reasonable detail the nature of the defect. Such notice may be made by any one or more of the following methods:
 - By Post addressed to: Fluid Management Technology LLC, 25235 Dequindre Road, Madison Heights MI, 48071
 - By email to: support.us@fmtweb.com
2. A RMA number will need to be generated and an RMA form needs to be completed with the details of the request, contacting us by email at support.us@fmtweb.com automates this process.
3. Upon FMT verifying the validity and currency of the Product Warranty in respect of the Customer's claim, the Customer must upon request by FMT send the Goods to FMT or FMT's authorized representative .
4. The customer must ensure that the Goods are properly packaged so as to ensure that no damage occurs to the Goods during transit. The Customer is responsible for all posting, shipping, freight and insurance charges in respect of the Goods returned to FMT. Whilst in transit, the Goods remain at the Customer's risk.
5. FMT may, in its absolute discretion reimburse the Customer for the Customer's cost to undertake such repairs to the Goods, provided that the Customer has first provided to FMT a written quote as to the estimated costs of the Customer undertaking such repair, and FMT has approved (in writing) the Customer to proceed with such repairs up to that agreed estimated cost.
6. Upon receiving the Customer's written quote, the Customer acknowledges that FMT shall have sole discretion as to whether FMT engages its own contractors to undertake the required repairs, or if the Customer may undertake such repairs.
7. The customer agrees that FMT shall have no obligation or liability to reimburse the Customer for the costs of any repairs undertaken by the Customer that have not been agreed in writing with FMT beforehand.
8. FMT reserves the right at its sole discretion to determine whether to replace or repair, free of charge, any part or parts, or the entire Goods.
9. The customer is responsible for all packaging, posting, shipping, freight and insurance charges in respect of any Goods returned by FMT to the Customer. The Customer agrees to pay such charges upon the same payment terms as apply to FMT's sales of Goods current at the time of the Product Warranty claim. Whilst in transit, the Goods remain at the Customer's risk.

1.7.3 General Exclusions and Limitations of the Warranty

1. The Product Warranty is limited to replacement or repair of defective parts or defects in workmanship and does not include any labor costs (whether such labor costs are supplied by FMT or the Customer).
2. In the event that no identical parts are available to repair the defective Goods, FMT has the right to replace the Goods with similar Goods of equal age and condition as the defective Goods, or offer the Customer the choice to upgrade the defective Goods. These may incur additional costs to the Customer and the Customer in those circumstances agrees to pay those additional costs upon the same payment terms as apply to FMT's sales of Goods current at the time of the Product Warranty claim.
3. Replacement Goods or parts may include re-manufactured or refurbished parts or components. Repaired or replaced Goods will continue be warranted for the remainder of the Product Warranty from the Warranty Commencement Date.
4. The Product Warranty does not cover consumables, including but not limited to batteries and surge protectors.
5. The Warranty will not apply, and FMT will be under no obligation or liability whatsoever if, in the opinion of FMT, the Goods have been:
 - (i) installed and maintained other than in compliance with FMT's product specifications, instructions and directions;
 - (ii) installed or used other than in a manner approved by FMT as suitable for the Goods;
 - (iii) handled in a manner which contravenes any direction, instruction or warning issued by FMT from time to time;
 - (iv) misused, abused, changed or damaged in any way;
 - (v) tampered with, including if any factory applied serial number has been changed or removed from the Goods;
 - (vi) damaged through normal wear and tear including exposure to the elements (on exposed and unexposed surfaces), exposure to unusually corrosive conditions, rust, or entry by any insect, vermin or foreign object in the Goods;
 - (vii) damaged as a result of connection to irregular voltage sources, voltage supply problems, power surges and dips, thunderstorm activity, result of a natural disaster, or acts of God (including fire, flood, lightning).

1.8 Recommended Tools for Installers

The following tools are required for SmartFill GEN 3 service and installation:

- Digital Multimeter, preferably with a DC voltage resolution of 3 digits. **We use and recommend the Fluke Model 117 True RMS Multimeter.**
- **A good quality small electrical flat blade screwdriver.** Poor quality screwdrivers do damage to terminals and prevent sufficient tightening of electrical terminals etc.
- A general set of flat and Philips VDE screwdrivers.
- Metric and Imperial VDE Hex (Allen) keys. Long ball head types are recommended.
- A cordless drill, with backup batteries.
- Metal Holesaws, sizes 16mm, 20mm, and 32mm.
- Flat and round files (for deburring metal holes).
- Pointed, and Side cutting pliers.
- Multi-Grip type pliers.
- Metric tape measure.



- The following tools are highly recommended, they make working with SmartFill GEN 3 easier:
 - Deep 10mm and 13mm VDE sockets, 1/4" or 3/8" drive with long extensions.
 - 1/4" drive VDE screwdriver handle with 7mm and 7/32" deep sockets fitted. The ends of the sockets should be machined or carefully ground down to reduce diameter at the end of the sockets.
 - 3/8" x 7/16" Open End VDE Spanner.
 - 13mm Open End / Ring VDE Spanner.

1.9 Pre-Installation Checks

Check the condition of the SmartFill GEN 3 and its associated parts when opening. Tell your SmartFill GEN 3 supplier immediately if items are damaged or missing. Its obviously best to carry out this check prior to traveling to the job.

- Check for the following items:
 - The SmartFill GEN 3 Control Box.
 - 20 vehicle NFC Fobs with keytags.
 - USB.
 - Mounting kit.
 - SmartFill GEN 3 installation manual.
 - SmartFill GEN 3 envelope with security code inside for website setup.

1.10 Safety Related Inspections and Preventative Maintenance

SmartFill GEN 3 units require no preventative maintenance to retain its user safety features. Whenever a SmartFill GEN 3 is updated or repaired, a safety inspection should be performed including wiring integrity (power and grounds), board retention and safety covers. We suggest regularly cleaning the unit to prevent build ups of dust or debris that can cause a hazard.

1.11 Cleaning Instructions

The SmartFill GEN 3 chassis, keypad & LCD glass should be washed with a mild detergent diluted with water. A soft sponge or cloth is recommended. Rinse and dry with a soft dry cloth. The SmartFill GEN 3 works well and presents no safety problems when dirty. Frequency of cleaning is left to the user's discretion.

1.12 Support

Fluid Management Technology may be contacted at support.us@fluidmt.com.

Chapter 2

SmartFill GEN 3 Installation and Configuration

2.1 Mounting the SmartFill GEN 3

2.1.1 Choosing the Location

The position for mounting of the SmartFill GEN 3 is to be determined by the installer, who should also consult the owner prior to a final decision.

WARNING

1.  Positioning and Location of the SmartFill GEN 3 MUST be in accordance with electrical regulations.

WARNING

2.  Location must be in accordance with hazardous area regulations, with regard to flammable zones etc.

WARNING

3.  The SmartFill GEN 3 is NOT approved for use in a hazardous / flammable zone.
4. The SmartFill GEN 3 manufacturers can not provide advice with regard to hazardous zones.
5. The installer is responsible for correctly selecting the location of the SmartFill GEN 3.

Only after the above regulations have been satisfied can you proceed further.

2.1.2 Mount the SmartFill GEN 3 to the pump / flowmeter

WARNING

-  Take precautions not to damage internal SmartFill GEN 3 components when drilling into the enclosures. You may need to remove internal components while drilling to prevent damage.

WARNING

-  Always wear a dust mask for breathing protection when drilling enclosures.

Providing that the SmartFill GEN 3 meets the requirements as specified in the section 2.1.1 above, then the following should also be considered prior to installation.

- The height of the SmartFill GEN 3 enclosure for operators ease of use / access.
- The door can be opened far enough to easily service the unit.
- Where possible, face the door away from prevailing weather.
- The SmartFill GEN 3 does not impede access to the pump for servicing.
- In very hot areas, if possible face the SmartFill GEN 3 display away from morning / evening sunlight. i.e.: face the display North or South.

2.1.3 Mounting Dimensions

SmartFill Gen 3 Units come in a single size. In the back page of this manual is a template for drilling holes that line up with the SmartFill.

- Enclosure outside dimensions in inches, 11.81w x 17.72h x 6.89d.
- Suggested mounting hole dimensions in mm, 4 x 11mm Holes, 8.66in across and 17in down.
- Mounting Bolts, 4 of 8mm x 30mm Zinc Set Screw with Nut and Flat washer.

NOTE- For vehicle mounting, it is recommended that the enclosure be mounted by drilling into the enclosure and fitting more securely.

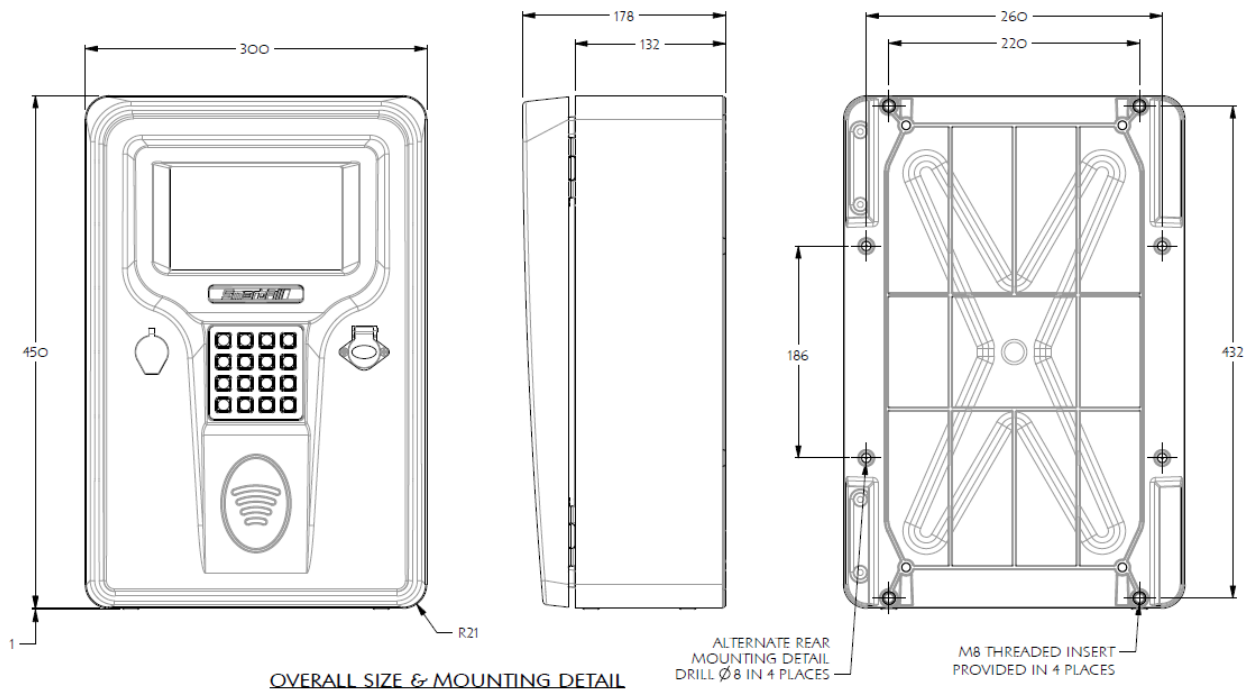

Figure 2.1: SF3 Enclosure mounting dimensions.

2.1.4 Seals

The SmartFill GEN 3 enclosure, the pre-installed seals and gaskets on the door and external facing components ensure no water can enter the unit.

The door on the SmartFill GEN 3 should be hard to close and depending on the location it is mounted, may require pressure applied to the front and rear of the unit simultaneously while the lock is engaged.

It is recommended that upon installation some desiccant silica gel packets are placed in the bottom of the SmartFill unit to prevent damage to the electronic components in the unlikely event moisture occurs in the unit.

WARNING



Modifications to the lock cam or lock tightness may let moisture to enter the unit.

2.2 Power Wiring

2.2.1 General Warnings

WARNING



WARNING

- Power wiring must only be installed / connected by suitably qualified personnel.
- Wiring must be safe and in accordance with all relevant National and Local / Site Standards.
- Wiring / conduit etc. must be suitable for the particular zone / area.
- Low voltage pulser wiring MUST NOT be contained in the same conduit as high voltage wiring.

2.2.2 Conduit Requirements

2.2.2.1 Conduit Size

The recommended conduit size is 3/4 inch. Wire sizes and quantities permitting, a limited number of 1/2 inch conduit may be used. The number of required conduit will be dependent on the application and the number of connected fuel dispensers and options.

2.2.2.2 Conduit Fill Capacity

The NEC states conduit will not be filled greater than 40% fill capacity. If the conduit terminates in a seal-off, seal-offs cannot exceed 25% fill capacity unless listed for larger volumes. Table 2.1 shows the available area within different size rigid metal conduit at full 40% and 25% capacity.

Conduit Size	Total Inside Area	40% Area	25% Area
1/2	0.314	0.1256	0.0785
3/4	0.549	0.2196	0.1373
1	0.887	0.3548	0.2218
1-1/4	1.526	0.6104	0.3815
1-1/2	2.071	0.8284	0.5178
2	3.408	1.3632	0.8520

Table 2.1: Rigid Metal Conduit Fill Capacity

Table 2.2 shows the cross sectional area of different wire sizes used with a SmartFill GEN 3 installation. You can estimate the NEC requirement by adding the cross sectional area of all the wires you intend to pull through a conduit, then comparing it to the maximum(40% or 25%) fill capacity of the conduit being used. If you are exceeding the fill capacity, additional or larger conduit will be necessary.

Wire/Cable	Diameter	Area
18 AWG TFFN	0.0841	0.0055
16 AWG TFFN	0.096	0.0072
14 AWG TFFN	0.111	0.0097
12 AWG TFFN	0.130	0.0133
10 AWG TFFN	0.164	0.0211
Belden 8723	0.160	0.0201
Belden 9552	0.368	0.1064

Table 2.2: Typical Wire/Cable Cross Sectional Area

2.2.2.3 Conduit Applications

See Figure 2.3 for a sample site layout including conduit requirements that have projected in accordance with the NEC. Be sure to check local codes for compliance. The SmartFill GEN 3 installation requires, as a minimum, a conduit for power and a conduit to each dispenser for control and pulse wiring.

Ensure that the junction box in the dispenser is of sufficient volume for the application.

Conduit entering a SmartFill GEN 3 typically enter through the opening in the bottom of the unit. If conduit enter the SmartFill GEN 3 through holes punched/drilled through its exterior, then the holes must be sealed to prevent water intrusion into the SmartFill GEN 3. Keep in mind, conduit entering the SmartFill GEN 3 through holes punched/drilled into the exterior of the unit will make it more difficult to move the SmartFill GEN 3 should it need to be moved/relocated.

SmartFill GEN 3 should have a NEC approved conduit seal on each end. These seals must be installed on accordance with NEC guidelines. In addition, sheathed cables are required to be cable sealed on accordance with NEC guidelines. Where flexibility is needed, approved explosion-proof flexible conduit may be used inside the dispenser housing between the conduit seal and dispenser junction box to make conduit connections.

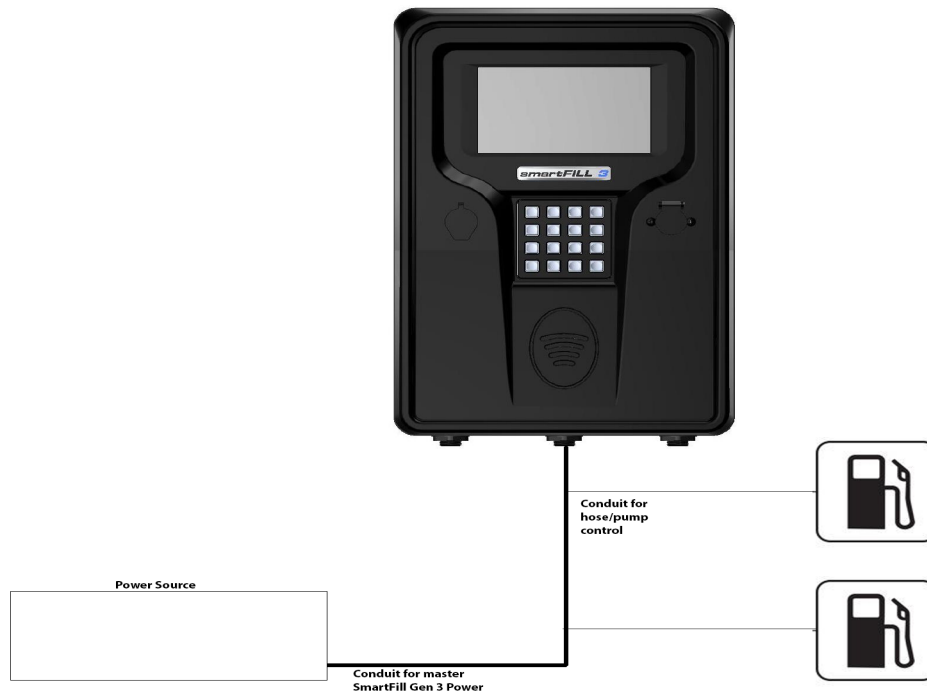

Figure 2.2: Sample Site Layout

2.2.3 Emergency Stop Switch Recommendations

- Estops are required by NFPA 30A.
- It is recommended, though not mandatory that emergency stop switches only disconnect power to the fuel pumping system, but not to disconnect power to the SmartFill GEN 3. This is to ensure that a fuel delivery is recorded correctly in the event an Estop switch is operated. Some sites will use the Estop to stop the pump in normal operation, and in such cases the risk of data loss / corruption is higher if power is disconnected by the Estop. However should regulations require the complete powering down of the system as well as the SmartFill GEN 3, then it should be clearly marked that the Estop is for emergency use only, not to be used to simply stop the pump.

2.2.4 Backup Generators

Some facilities are equipped with backup generators to supply AC power when the regular power supply goes down. During start-up of the backup generator the initial power surge may be extremely high until all connected equipment is restored to operation. This power surge has the same potential for damage to the SmartFill GEN 3 equipment as a lightning strike. Ensure the installed equipment is protected (regulated) from current surges during start-up of the backup power source. If possible, turn off the SmartFill GEN 3 power until non-regulated generator power stabilizes.

2.2.5 Bypass Operation



The Bypass Switches only apply to units using Hose/Pump modules. For pumps/bowers using protocol control, the pump must be placed into stand alone mode.

Setting the bypass switch in an on position will remove the SmartFill GEN 3 unit from dispensing operations. NO login/fob/key/PIN will be required to operate the pump. It is as if the SmartFill GEN 3 is not there. This mode also helps in fault-finding. If you cannot get fuel then set the bypass switch and see if you can get fuel. If you still cannot then the SmartFill GEN 3 is not responsible for the issue.

2.3 Termination of a Transaction

In SmartFill GEN 3 there are two ways that a transaction can be terminated:

1. At the expiration of the post walk time duration: if the walk time is set to 30 secs the transaction will be terminated if there is no flow of fuel for 30 seconds.
2. Using a nozzle switch. This relies on a switch which is opened and closed when the nozzle is lifted and replaced.
3. Using either a preset quantity of Currency or Volume.

Whichever option is used will determine what wiring is required to initiate the termination of a transaction

2.3.1 Nozzle Switch

On AC and DC switched SmartFill GEN 3 units it is possible to use an external nozzle switch to terminate the transaction. The nozzle switch must be located in a non-hazardous location. An external switch used for this purpose should be open when the nozzle is in place and closed when the nozzle is lifted. The relay on the pump module will only operate when the nozzle switch closes and stops when the switch is opened (back in the holster).

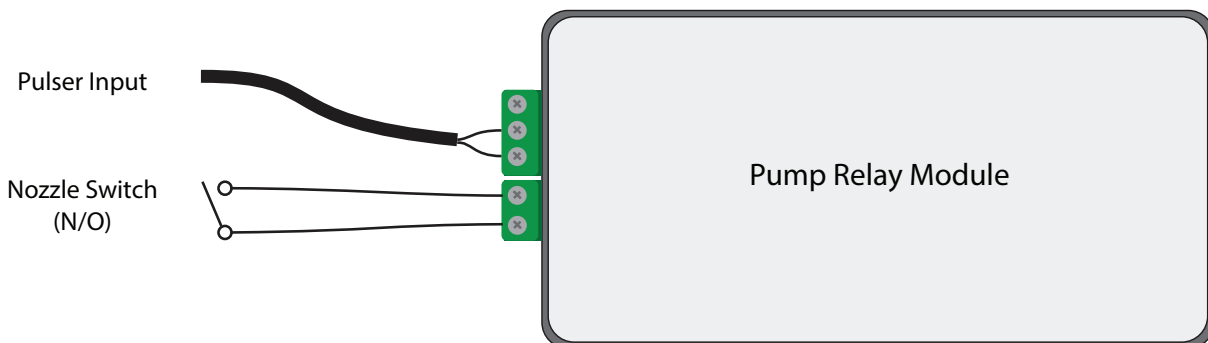

Figure 2.3: Nozzle Switch Wiring for AC and DC Pump Modules

2.3.2 DC Power Out

The DC Power Out socket provides 12VDC MOD, 0VDC and 12VDC. The output of this socket must remain below 400mA.

2.4 AC System Wiring

2.4.1 Single AC Wiring

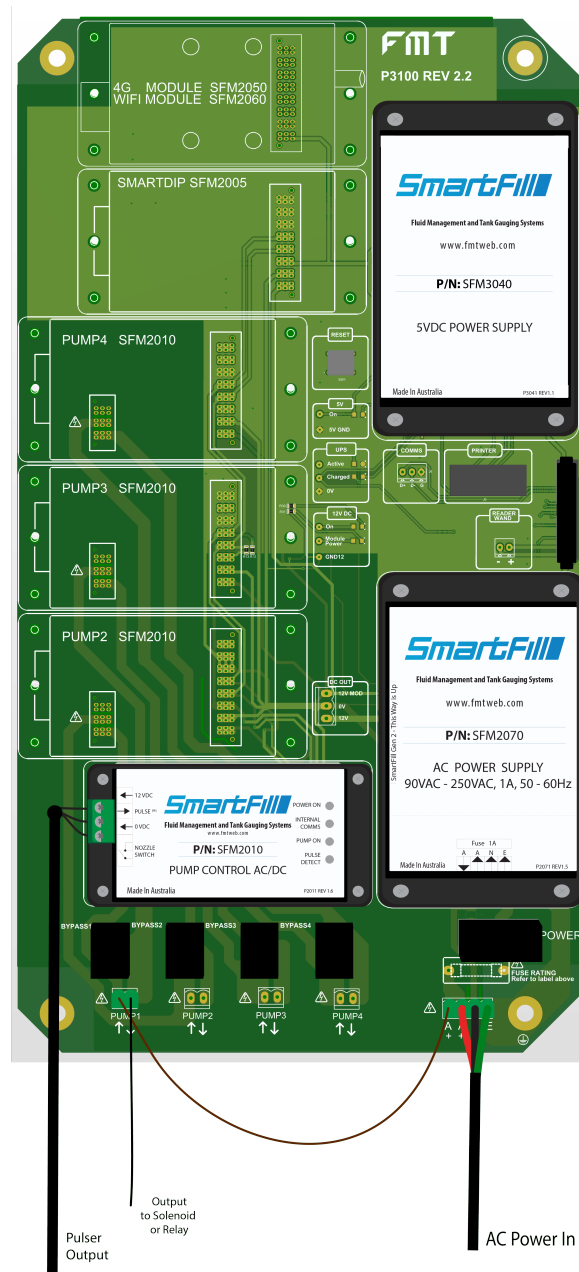

Figure 2.4: Wiring for Single Hose with Mains Switching

2.4.2 Dual AC Wiring Two Flowmeters

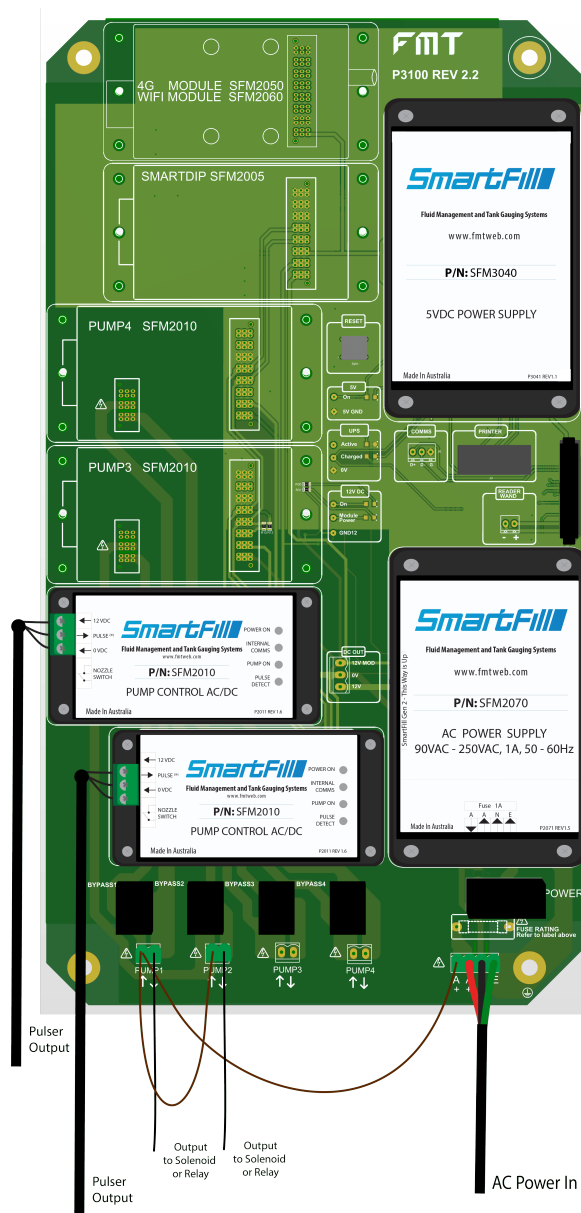

Figure 2.5: Wiring for Dual Hoses with Mains Switching and Two Flowmeters

2.4.3 Dual AC Hoses with One Flowmeter

AC powered SmartFill GEN 3 systems (NMI and NON NMI) can control 2 outlet hoses, while only connected to one flowmeter. While only letting flow through one hose at a time, it provides the following benefits:

- lets use of High and Low flow nozzles on separate outlets, as long as each outlet has a control valve fitted.
- Reduces cost of installation, requiring only one flowmeter.
- Prevents operators from using the two nozzles simultaneously.
- Meets NMI requirements for single flowmeter / 2 hose configuration.



In the pump menu (??) the pulser source should be set to pump 1.

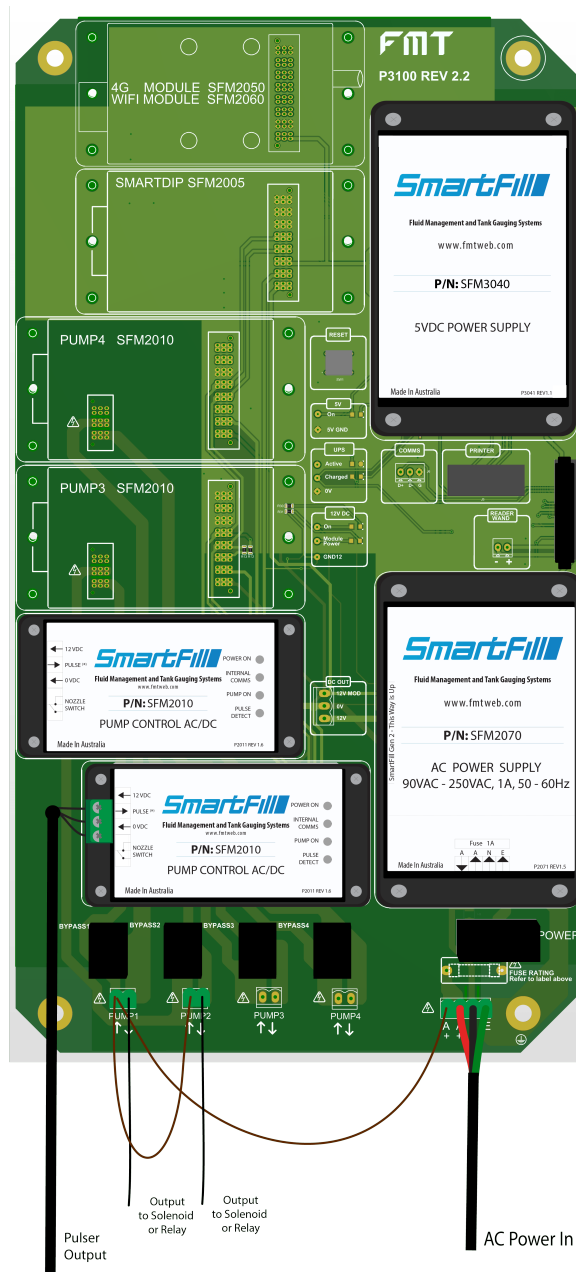

Figure 2.6: Wiring for Dual Hoses with AC Switching and One Flowmeter

2.4.4 Wayne CL

The Wayne CL module is also compatible with Bennett/Generic protocol.

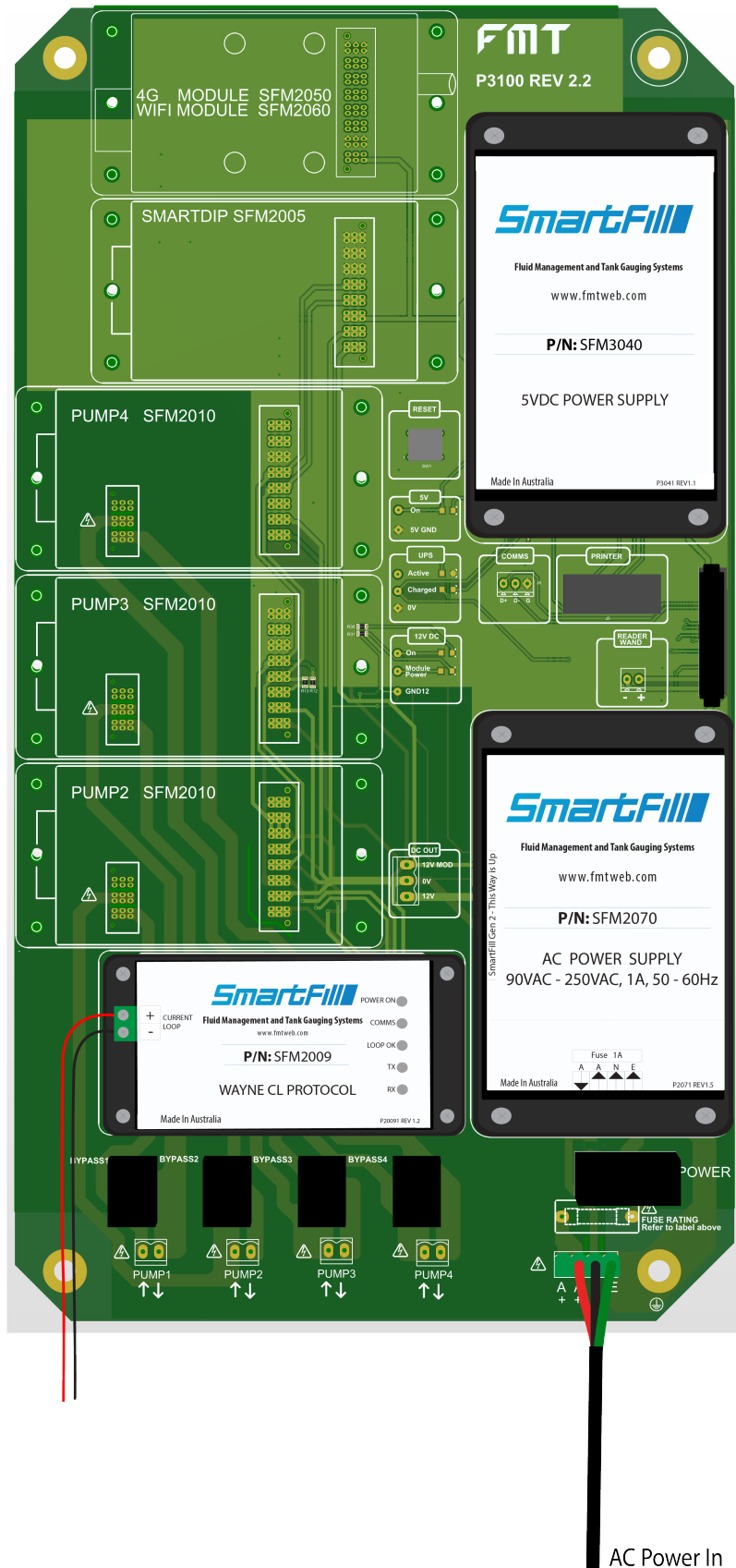

Figure 2.7: Wiring for Wayne CL Protocol

2.5 DC Wiring

SmartFill GEN 3 DC models can be powered by either 12VDC or 24VDC supplies and can switch DC voltages from 12 to 24VDC with maximum current of 5A.

2.5.1 Single Hose DC Switched

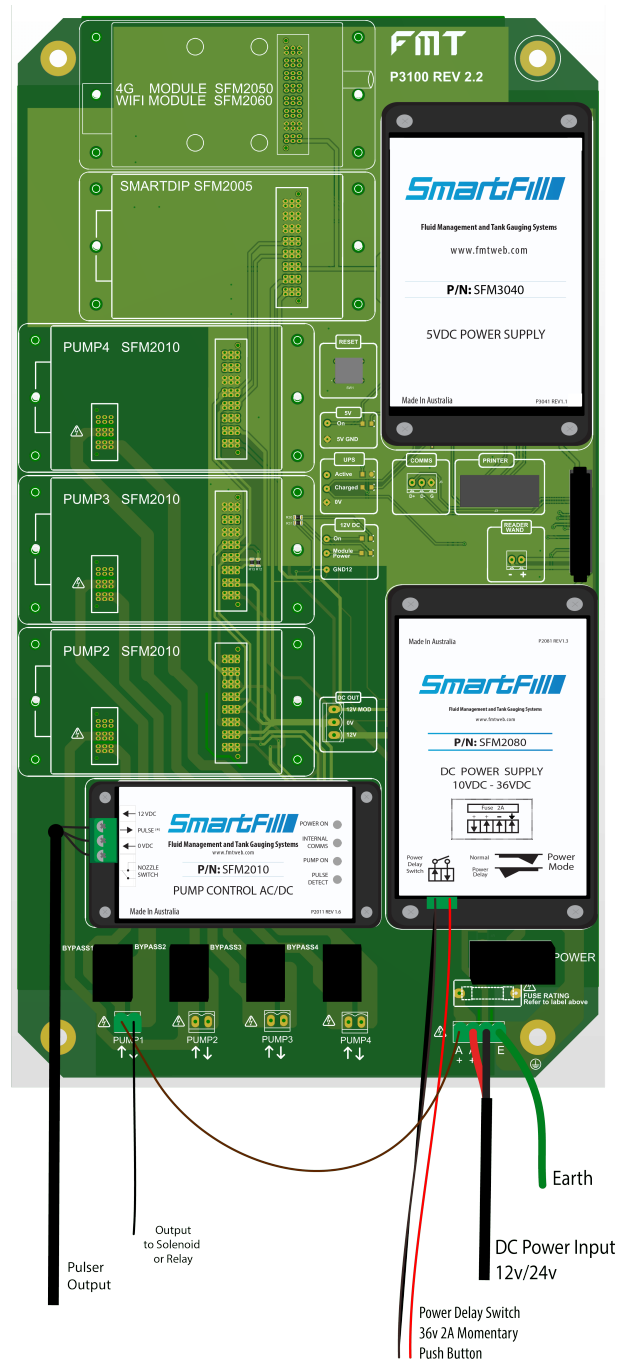

Figure 2.8: Wiring for Single Hose with DC Switching

2.5.2 DC Switched Dual Hoses with Two Flowmeters

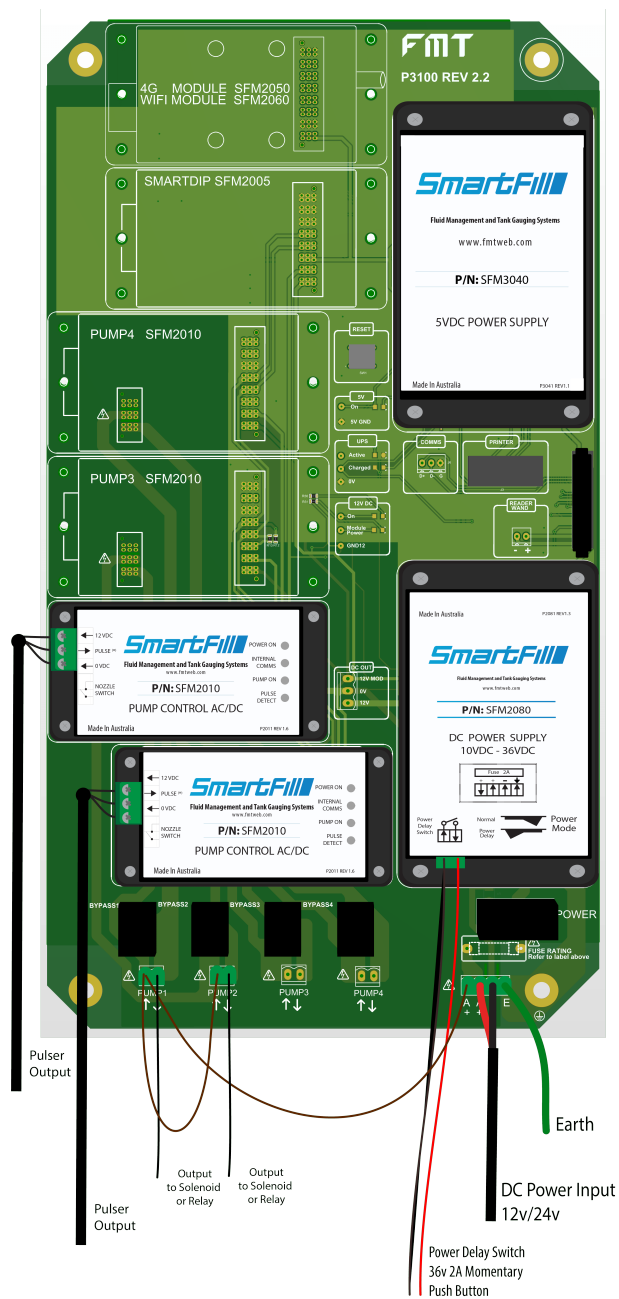

Figure 2.9: Wiring for Dual Hoses with DC Switching and Two Flowmeters

2.5.3 DC Switched Dual Pumps with Single Flowmeter

SmartFill GEN 3 systems (NMI and NON NMI) can control 2 outlet hoses, while only connected to one flowmeter. While only letting flow through one hose at a time. The unit must be fitted with two relay modules to make this work. In the pump menu for pump two the module one should be selected as the source. (refer to pump set-up menu) it provides the following benefits:

- Allows the use of High and Low flow nozzles on separate outlets, as long as each outlet has a control valve fitted.
- Reduces cost of installation, requiring only one flowmeter.
- Prevents operators from using the two nozzles simultaneously.
- Meets NMI requirements for single flowmeter / 2 hose configuration.



In the pump menu (??) the pulser source should be set to pump 1.

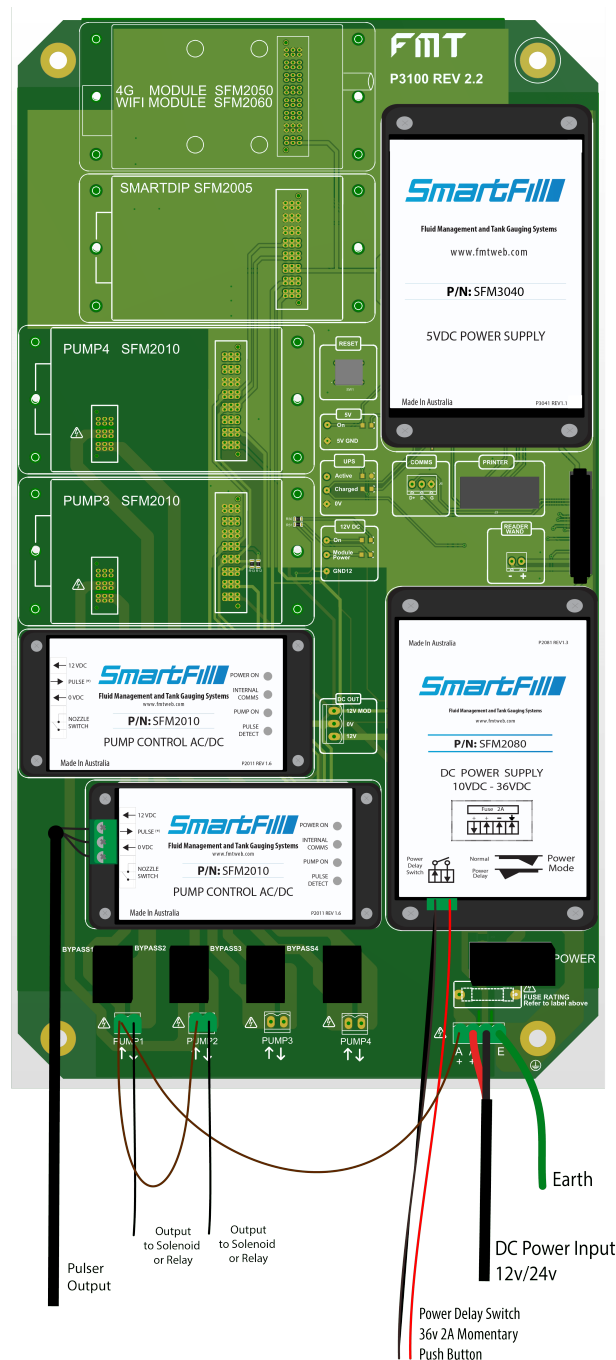

2.5.4 DC Systems Delay Power Off Option

2.5.4.1 Auto Power Off

NOTE- This option is applicable to DC powered systems.

The Delay Power Off option has a number of benefits, suiting a few applications. Delay Off simply means that the SmartFill GEN 3 will power itself off fully, after a timeout period following a fuel delivery. This also requires the operator to power the SmartFill GEN 3 On via a push button .

To enable "Auto Power Off" on a SmartFill GEN 3:

1. Fit a normally open switch to the SmartFill unit either mounted into the front door or some location convenient for the user.
2. Check that the power supply / push-button wiring is correct for this configuration.
3. Set the " Power Off" option in the Power menu.

2.5.4.2 Auto Power Off Wiring

Correct wiring for SmartFill GEN 3 when connected to a 12v system, the main functions being:

1. Disconnect power to the SmartFill GEN 3 after a preset time following a fuel delivery, preventing the SmartFill GEN 3 from draining a vehicle or engine battery.
2. Reduce total daily power consumption so that solar power equipment costs can be minimized.
 - The timeout period is adjustable in the SmartFill GEN 3 MENU from 1 to 59 Minutes. Normal setting 15 minutes.

2.6 Pulser Installation

2.6.1 Pulse input theory

The SmartFill GEN 3 processor board measures fuel quantity by counting pulses from the flowmeter or a pulse transmitter, and changes these pulses to a quantity in Liters/Gallons.

Some types of flow meter have a pulse output built in to them, and the flow meter sends out pulses at a set rate per gallon of fuel flow.

On other systems it may be required to install a pulse transmitter onto a rotating shaft etc., to change the fuel flow into a pulse output. The SmartFill GEN 3 manufacturers make pulse transmitters to suit the most common flowmeter registers (mechanical bowser counters).

Pulse transmitters generally use 1 of 3 types of switching device to generate the pulses. They are listed below in order of preference.

1. **Hall Effect Switch:** A small 3 pin device which outputs a pulse when a magnet passes. These are the preferable type of pulser, and have a very long life span, being a solid state device.
2. **Reed Switch:** A small 2 pin device in a glass tube. The 2 contacts inside the tube come together when a magnet passes, creating a circuit. Reed switches can cause problems if the contacts 'bounce' or are dirty, and they do have a set life span.
3. **Optical Switch:** A 4 or 5 pin slotted device which has an LED light source shining onto a receiver, and when the light path is broken by a slotted wheel etc., the receiver outputs a pulse. These pulsers will eventually fail in a dirty environment, so must only be used in dust free areas.

IMPORTANT It is best practice to use a Hall Effect type flowmeter / pulser wherever possible.

The supply voltage for the Pulser must be at least 12VDC and the Output **MUST** be open collector.

2.6.2 Pulser Application Chart

Part No	Description	Hazardous Zone Approved	Suits Pump / Flowmeter Types
A1020	SmartFill GEN 3 Optical Pulser Kit	NO	Fill-Rite or similar style open frame 3 or 4 digit mechanical register.
A1024	SmartFill GEN 3 Hall Effect Pulser Kit	NO	Gilbarco T334 Fleetline, or a Pump fitted with a Veeder-Root 1623 Series Register
A1025	SmartFill GEN 3 Hall Effect Pulser Kit	NO	LC / FPP / TCS or a Flowmeter fitted with a Veeder-Root 7887 Series Register

Table 2.3: Pulser Application Chart

Connection to Flowmeter

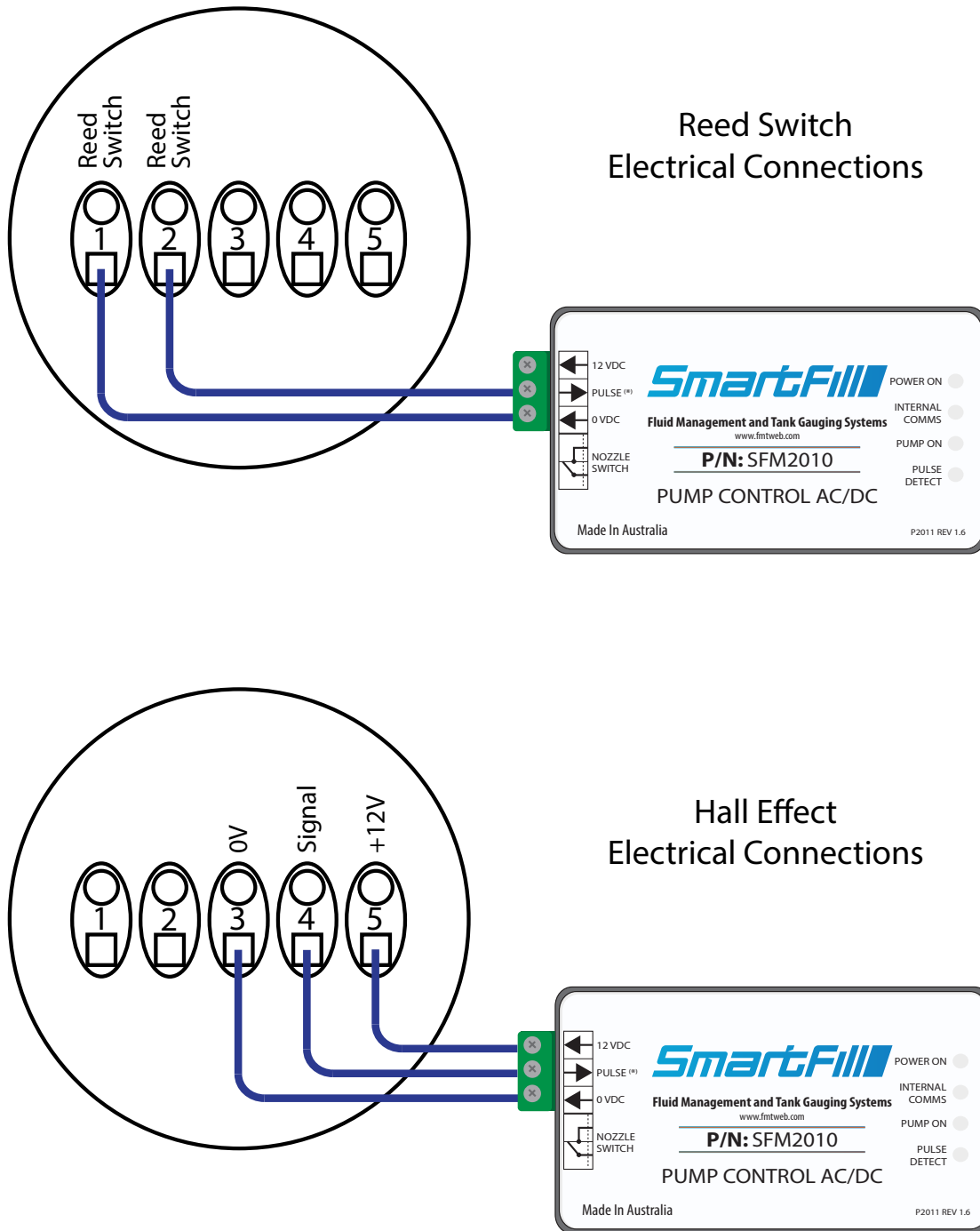

Figure 2.11: Connection to Flowmeters: Reed and Hall Effect Sensors

2.6.4 Gasboy® 9800A or 2600A Pump Interface Kits Pulse-out I/F Board (M06587A001) Jumper Settings

Jumper Settings		
	Single-channel, Dual/Single-hose Pulse-out I/F(Default Setting)	Dual-channel, Single-hose Pulse-out I/F (C07357 kits)
Wire Color	JP1 Position 1 JP2 Position 1 JP3 Open	JP1 Position 2 JP2 Position 2 JP3 Open
Red	Pulse-out Side 1	Pulse-out Side1A
Green	Pulse-out Side 2	Pulse-out Side1B
White	Common Return	Side 1A Return
Black	No Connection	Side 1B Return

Figure 2.12: Gasboy Interface Kits

Jumpers JP1, JP2, and JP3 This Board Assembly can be configured for use in one of the following pump/dispenser configurations: ●Single-channel, Dual/Single-hose Pulse-out I/F (see Figure 2.14) ●Dual-channel, Single-hose Pulse-out I/F (see Figure 2.15) The chart below shows the jumper settings and wires to connect to in the Junction Box, based on the configuration. Check JP1 - JP3 jumpers and change them, if necessary. The jumper settings must be changed only when the power to the pump/dispenser is removed, to protect the circuit that they are connected to. For models 9800A, 2600A, or 9800Q, the P3 connector is not connected.

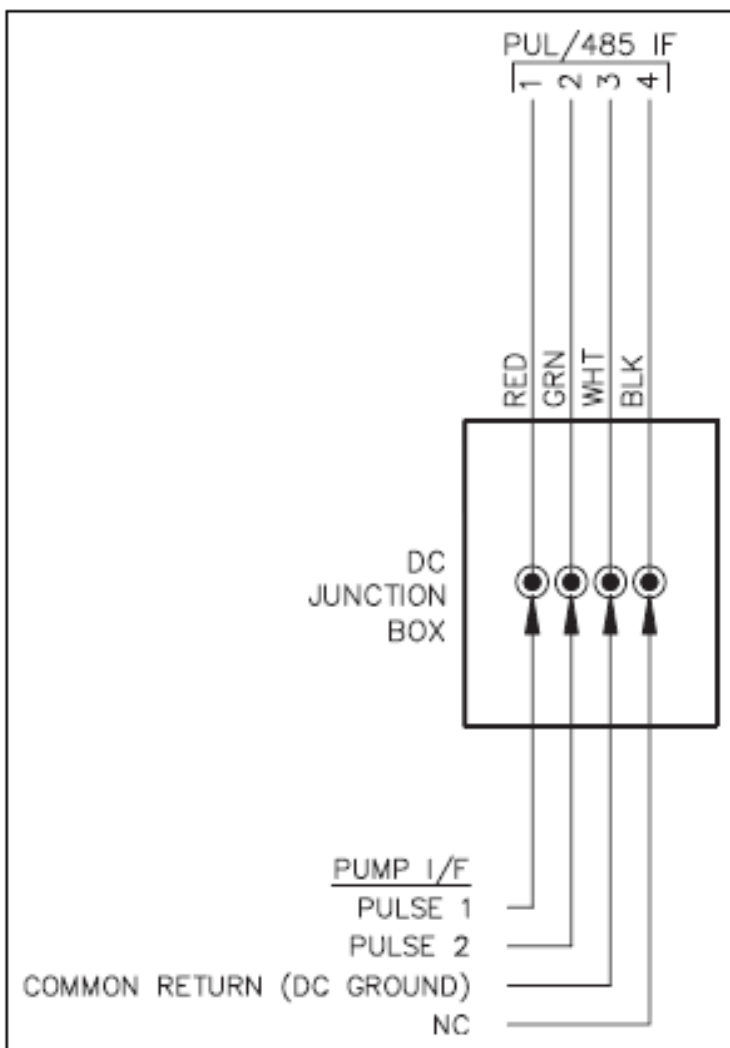

Figure 2.13: Dual Pulse Input

Jumpers JP4 and JP5 When this board is used in a model A or Q pump/dispenser or 9850K, jumpers JP4 and JP5 are set to the Q/A position. Figure 2.14 illustrates the proper output for using a Pump I/F Board (M06587A001) jumpered to provide two pulse outputs, one from each Pulser (C06482 kits).

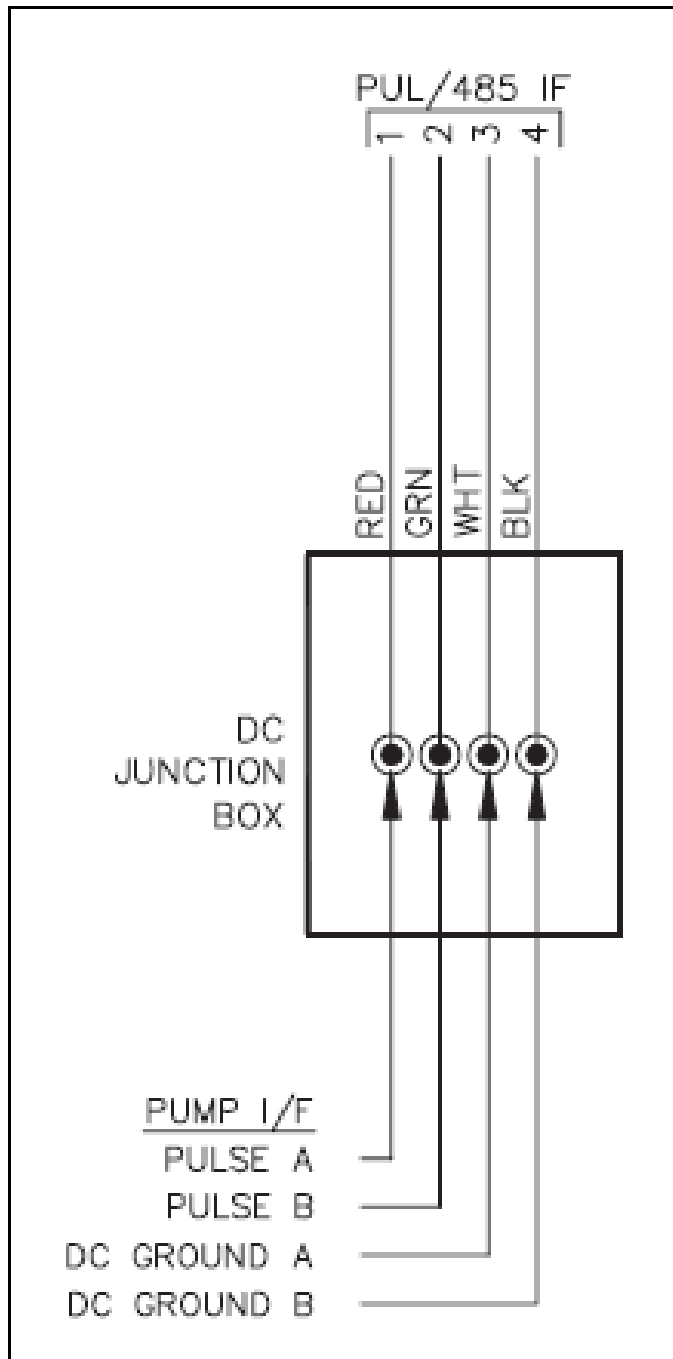
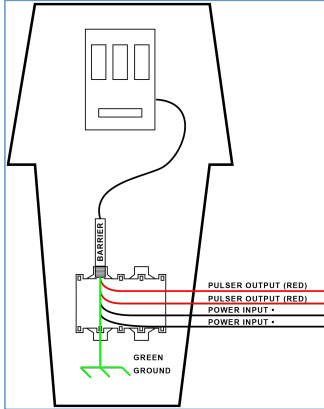

Figure 2.14: Dual Pulse from Single Pulsers

Figure 2.15 illustrates the proper output for using a Pump I/F Board (M06587A001), jumpered to provide two isolated pulse outputs from a single Pulsers (C07357 kits). This option is available only for 9800A or 9800Q single pumps/dispensers. Note: 1) All wiring and conduit runs must conform with all building/fire codes, all Federal, State, and Local codes, National Electrical Code, (NFPA 70), NFPA 30, and Automotive and Marine Service Station Code (NFPA 30A) and regulations. Canadian users must also comply with the Canadian Electrical Code.

2) Refer to MDE-4341 Series 9800A/9800Q Pump and Dispenser Installation/Operation Manual for complete installation instructions.

Model 800-F Pulser



Wire Connections

Pulser Type (P/N)	Black Wire	Black Wire	White Wire	Orange Wire	Violet Wire	Red Wire	Green Wire
110 VAC (4000800-F)	110 VAC Hot	N/A	Neutral	N/A	N/A	Pulse Output	Ground
12 VDC (4000800-F-12)	DC Ground	N/A	N/A	+12 VDC	N/A	Pulse Output	Ground

Pulse outputs (red wires) will pulse any voltage from 5 to 170 VAC or VDC
N/A = Not applicable for this version

ETL CLASSIFIED



NOTE: Unit to be installed in an enclosure suitable for Class 1 Division 1

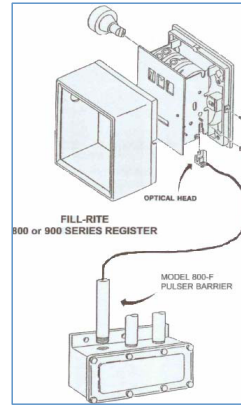

INSTALLATION

1. Remove the reset knob and cover from the register.
2. (If EQUIPPED) Remove the nut and washer from the shaft screw on the left side of the register (later model registers are built with a smooth shaft).
3. Place the optical head such that it straddles the plastic gear on the end of the shaft and the bracket slot in on the shaft screw.
4. (If EQUIPPED) Replace the washer and nut removed in step 2. On late models, secure the optical head with the supplied push nut.
5. Replace the register cover and reset knob.
6. Install the barrier into the junction box.
7. Connect the power wires according to the drawing provided. Pay particular attention to the part number of the pulser you are installing to match the proper wire colors to the proper connections.
8. Connect the red wires to the pulsing circuit.

If erratic operation of the pulser is encountered, it may be due to electrical noise or fluctuations of the power lines. This type of problem can be eliminated by powering the pulser with separate power lines not connected to motors or solenoids, or by adding noise suppressors to each motor and/or solenoid.

All appropriate wiring practices as outlined by the National Electrical Code and state and local codes should be followed.

Contact OPW Fuel Management Systems in case of trouble or unusual application.
Telephone 708-485-4200 FAX 708-485-7137

Figure 2.15: Model 800 Pulser

2.6.6 Bennett Pulse Output wiring

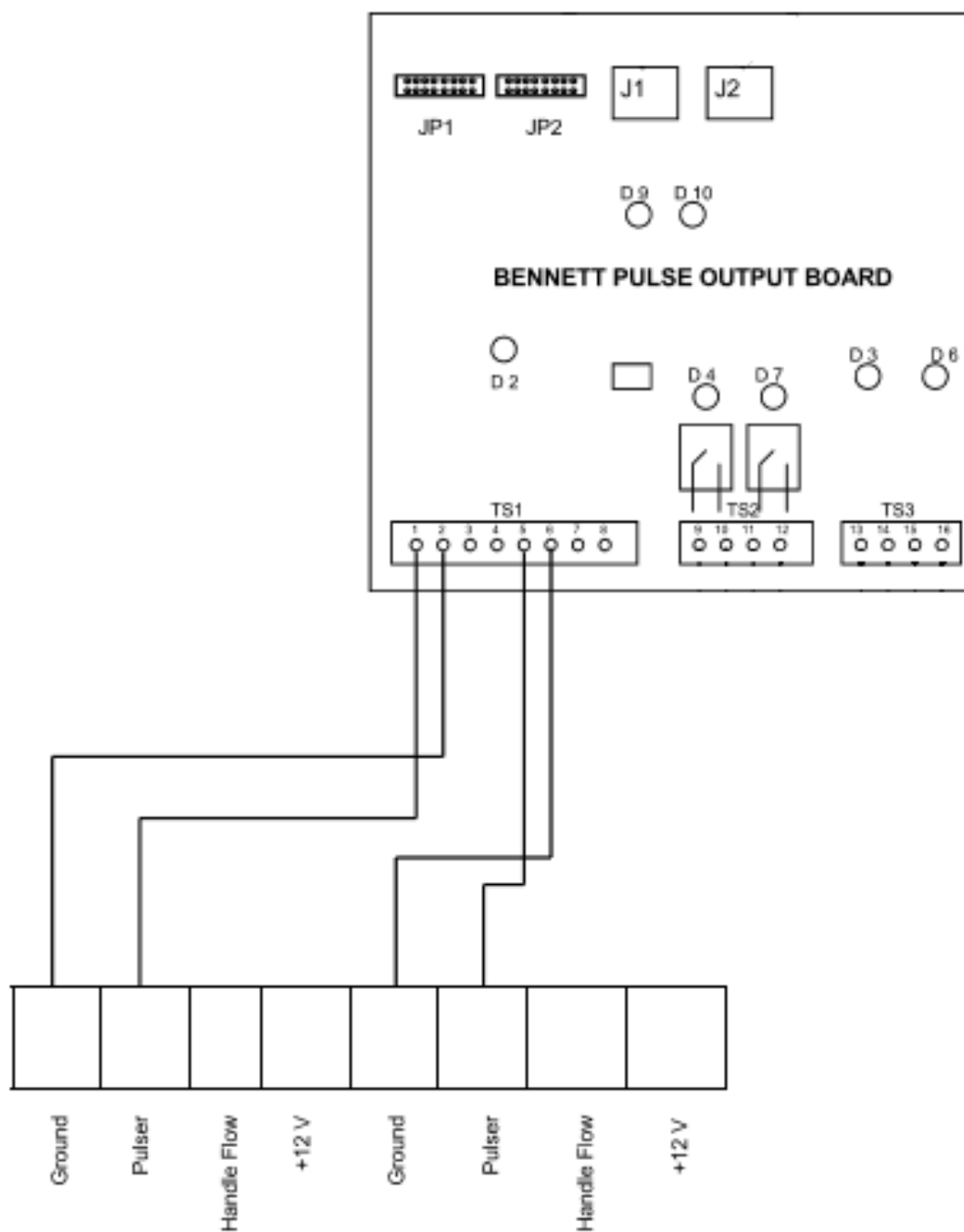

Figure 2.16: Bennett Pulsar Wiring

IMPORTANT NOTE: This drawing provides typical wiring installation for a dual hose unit. Duplicate wiring for multi-hose installations. For more wiring and setup procedures, refer to the dispenser installation manual.

2.7 Calibrating and Testing the Unit

To calibrate the unit you must first add a test key or code (for vehicles the default is key) to the system. You can then calibrate the unit using one of two methods:

1. Set K factor
2. Auto calibrate



When the SmartFill is controlling a bowser using a two wire protocol, such as Gilbarco or Compac the calibration is done in the bowser and the SmartFill reads the quantity of fuel dispensed at the end of the transaction: there are no calibration options in the SmartFill for this configuration.

2.7.1 Adding a Test Key

Access the Installation Setup Menu using the installer PIN. The default installer PIN is: **6789**. To access the PIN entry screen hold down the **CLR** and keys **ENT** together for a couple of seconds until the display reads "Enter admin or installer PIN", then enter the required PIN. Once your PIN has been accepted you will be presented with the following menu:



Figure 2.17: Installation Menu

To select a menu item push the related key on the keypad. To add a test key, push <1> for Vehicles then push <1> for "Add" and then hold up the key/fob to the detection point. The display will indicate when a key has been successfully added. This key can be used for calibrating the unit.

2.7.2 Calibrate by setting the K-Factor

This procedure only applies to units using pump modules. For units using pump protocol modules, the calibration is done at the bowser.

- The SmartFill counts the number of pulses received while delivering fluid, and changes the number of pulses to a volume in gallons as each pulse is received. The method of adjusting the calibration is known as a 'K-Factor'.
- Adjusting the K-Factor value upwards makes the SmartFill read higher compared to the quantity of fluid dispensed.
- You can use a known size measuring container (known as a Weights and Measures Container, and is normally 5 gallons in size), or you can use the display on the meter or dispenser if fitted.
- The measuring vessel size or quantity delivered should be as large as possible.

1. If you have a known size measuring container

- (a) Accurately fill the measuring container.
- (b) Look at the SmartFill display and note the gallons recorded.

2. If you have a display on the dispenser/meter

Before adjusting the SmartFill K-Factor by using the display on a dispenser or meter, the meter should be calibrated with a measure to ensure that it is delivering the quantity actually shown.

- (a) Fill a container or vehicle fuel tank.
- (b) Record the gallons recorded on the SmartFill and the dispenser.
- (c) The formula for calculating the new K-Factor is: **Existing K-Factor * gallons shown on SmartFill / gallons delivered .**

Eg:

The existing K factor is 1000.

The volume recorded by the SmartFill was 5.2 gallons

The delivered quantity was exactly 5.0 gallons.

New K factor = $1000 * 5.2/5.0 = 1040.$

3. If your meter has a K-Factor provided

If the meter you are using has a K-Factor provided by the manufacturer, you can use that K-Factor for the calibration.

4. To set the K-Factor manually

- (a) Hold down the **CLR** and **ENT** keys at the same time and when prompted for an access code enter **6789**.
- (b) Press **8** to enter the pump menu and then select the number corresponding to the pump you want to calibrate e.g 1 for pump one.
- (c) Press **4** to enter the set K-Factor menu.
- (d) Enter the required K-Factor and press **ENT**.
- (e) Repeat the process until measurement is consistently accurate.

2.7.3 Setting the K-Factor using Auto Calibrate

The auto calibrate function calculates and sets the K-Factor for you after you have dispensed a set quantity of fuel into a measure or determined it by using a display on a register or dispenser.

1. The process to auto calibrate is:

- (a) Press **5** in the pump menu to select Auto Calibrate
- (b) Enter the quantity of fuel to be dispensed e.g 15 gallons.
- (c) Press **ENT**. This will turn on the pump and you can start dispensing the required quantity
- (d) Once you have dispensed the required quantity of fuel, press **ENT** again and the unit will display the K-Factor it has calculated. This automatically overrides the existing K-Factor.

IMPORTANT – A large delivery of fluid enables a more accurate calibration. Calibrating with a small delivery of fluid can result in substantial precision errors. The recommended minimum calibration quantity is the quantity delivered at full flow for at least 1 minute.

2.7.4 Initial Suggested K Factors

Pulser / Flowmeter Type	Pulses per liter
A1020 SmartFill GEN 3 Fill-Rite Style	20
A1024 SmartFill GEN 3 VR1623 (Fleetline etc)	10
A1025 SmartFill GEN 3 VR7887	1
Flomec / Trimec 25mm Reed SW	27
Flomec / Trimec 25mm Hall Effect	107
Flomec / Trimec 40mm Reed SW	13
Flomec / Trimec 40mm Hall Effect	52.6
Flomec / Trimec 50mm Reed SW	6.465
Flomec / Trimec 50mm Hall Effect	12.93
Flomec / Trimec 80mm Reed SW	2.32
Flomec / Trimec 80mm Hall Effect	9.3
MacNaught M10 25mm	36
MacNaught M40 40mm	14.5
MacNaught M50 50mm	6.68
MacNaught M80 80mm	2.59
MacNaught M100 100mm	2.315

Table 2.4: Suggested Initial K-Factors.

2.8 Gilbarco Comms SmartFill GEN 3

2.8.1 Data Cabling

- The data cable used for Gilbarco comms purposes is ideally a twisted / shielded pair. The shielding is grounded at the SmartFill GEN 3 end, and left unconnected at the Dispenser end.
- Data cabling should be run separate to mains cabling.
- All cable ends **MUST** be insulated where insulation has been removed, to prevent shield wiring etc from touching circuit boards or metal parts.
- Bootlace ferrules must be used on all data connections.

2.8.2 Wiring Diagram

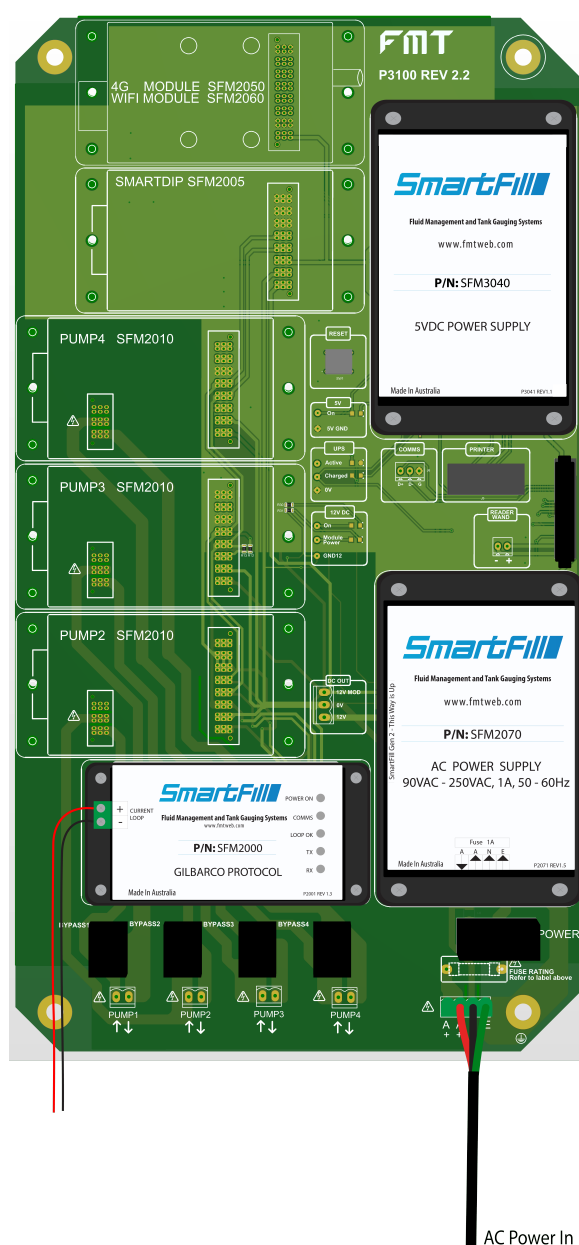

Figure 2.18: SmartFill GEN 3 Gilbarco Wiring diagram.

2.8.3 Gilbarco Communications

- The Gilbarco communications standard is a series communication loop which is powered by the controller, i.e.: the SmartFill GEN 3.
- The SmartFill GEN 3 can control up to 8 pumps with GB comms.
- Pumps can be turned on / off in the SmartFill GEN 3 pumps menu.

2.8.4 5 / 6 Digit purpose and setup

- The 5 /6 digit setting is a part of the Gilbarco comms system. In earlier model pumps only 5 digit was available. To allow larger fuel deliveries, the 6 digit setup was introduced. Some fuel dispensers are fixed at 5 digit, some at 6 digit, and some can be set to 5 or 6 on the pump. Speak to the pump manufacturer (not the SmartFill GEN 3 manufacturer) to confirm the configuration on a specific pump.
- All SmartFill GEN 3 systems can be changed from 5 to 6 digit. Even on multiple hose systems, each individual hose (pump) can be set as 5 or 6 digit. This lets you to mix the two on one site.
- When a pump transmits its Liters data to the SmartFill GEN 3, the decimal point position in the Liters is different with 5 and 6 digit formats. A dispenser set up as 5 digit Liters, can only transmit a maximum of 999.99 Liters to the SmartFill GEN 3, where as 6 digit setup can transmit 9999.99 Liters.
- If the setup on the SmartFill GEN 3 is incorrect, this will result in the SmartFill GEN 3 incorrectly reading the Liters data from the pump, i.e.: the decimal point will be in the wrong place.
- WARNING - Some dispensers will show 6 digits on the display, even when set in 5 digit mode. This results in a fuel delivery of over 1000 Liters losing the 'thousands', which is a serious problem.
- When it is possible, the SmartFill GEN 3 and the pump MUST be set to 6 digit mode.
- The SmartFill GEN 3 must only be set to 5 digit mode when a pump is locked on 5 digit.
- Use the 5/6 digit option in the pump menu to switch the SmartFill GEN 3 between 5 and 6 digit operation
- IMPORTANT.
The SmartFill GEN 3 manufacturers can not provide information on the 5 / 6 digit setup procedures for fuel dispensers. This information must be sourced from the pump supplier / manufacturer.

2.8.4.1 5 / 6 digit Liters setup procedure

5 or 6 digit operation is set up in the pumps menu in Installation Menu. refer to 2.13.8 - Pumps.

2.8.5 Gilbarco comms test procedure

HIGH VOLTAGE WARNING.

These checks must only be carried out by a suitably licensed and qualified electrician when there are mains voltages present.

This information is a basic test procedure for Gilbarco communications. This will simply tell you if there is current flow in the comms loop, and also if there is correct approximate voltage drop across the pumps in the loop.

2.8.5.1 Comms loop current check

The current flowing through the comms loop can be tested by using a digital multi-meter in DC milliamp mode.

1. Power the system off.
2. Disconnect the + comms wire from the SmartFill GEN 3 module.
3. Put the multimeter in DC Milliamp mode, in series with the loop.

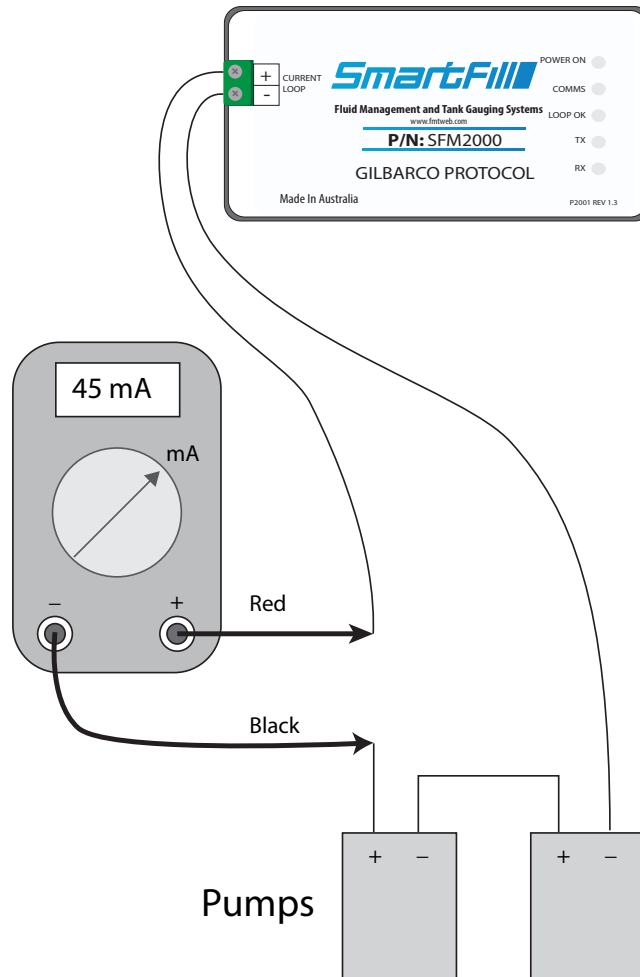

Figure 2.19: Multimeter set up to measure DC milliamp in the comms loop.

4. Power the system on, and measure the current flowing in the circuit.
 - (a) 45 milliamp is an ideal reading, but a range between 40 and 50 milliamp should still be OK.
 - (b) Over 50 milliamp would indicate a fault in the SmartFill GEN 3 board, as this supplies the current for the circuit. You should replace the SmartFill GEN 3 slave board.
 - (c) Below 40 milliamp would indicate a high resistance in the loop, or an open circuit. This could be caused by either a wiring issue, a faulty SmartFill GEN 3 slave board, or a faulty dispenser.
 - i. Disconnect the comms loop from the slave board, and connect the multimeter directly across the + and - terminals. If you now have 45mA, then the cable is faulty. If it is below 40mA, then the slave board is faulty, and should be replaced.
 - ii. Run a temporary comms data cable to each dispenser, to check the cabling. You can also run a cable to each dispenser individually to test each one.

2.8.5.2 Comms loop voltage drop check

A very simple check is to measure the DC voltage drop over the comms loop.

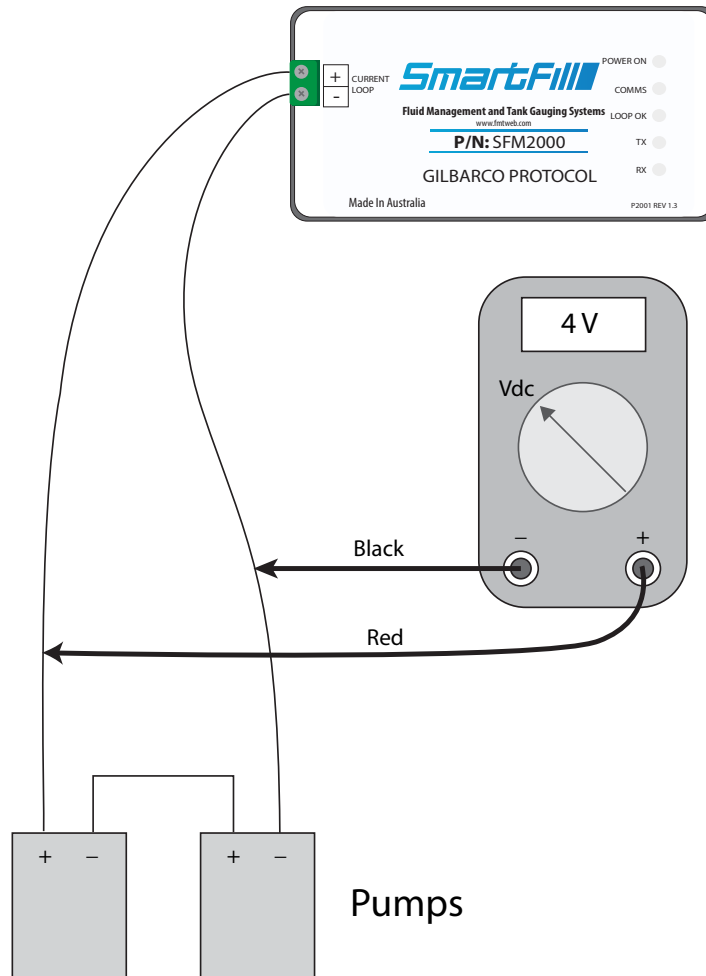

Figure 2.20: Multimeter set up to measure voltage drop over the comms loop.

With the loop disconnected from the SmartFill GEN 3 board, you should have a reading of approx 13 volts across the + and - terminals on the slave board.

With the loop connected, you should see a reading of approx 1.5 to 2 volts, for each pump on the loop. So if you have 3 pumps on the loop, a reading of say 4.5 to 7 volts would be permitted.

2.8.5.3 Troubleshooting

There are some common faults which can be encountered when installing a SmartFill GEN 3 with Gilbarco comms. Please thoroughly check each of the items below before consulting the SmartFill GEN 3 or Pump manufacturers for assistance.

PLEASE remember, the SmartFill GEN 3 manufacturers can NOT provide technical advice on fuel dispensers, or there setup processes etc. You must consult the pump manufacturers for specific pump advice.

Check off each item below as you test the system.

- No communication, "Pump comms link failed" showing the SmartFill GEN 3 display.
 - Check that the pump numbers in the dispenser are set correctly.
 - Check that pumps are set to self serve mode, not stand alone.
 - Check wiring, and ensure that the comms loop is connected correctly.
 - Check the loop current, and voltage drop readings, see section 2.8.5.
 - Try a power reset (Power off for 30 seconds) of the SmartFill GEN 3 and the dispenser. Do this with the dispenser nozzles hung up. Make sure you wait the full 30 seconds to ensure that the power is completely off. Also check the SmartFill GEN 3 display to check that the power has actually gone off.
- Liters reading incorrectly, i.e.: Decimal point is in the wrong place in the Liters shown on the SmartFill GEN 3.
 - This is simply the 5 / 6 digit setup in the dispenser and the SmartFill GEN 3. Refer to section 2.8.4.

2.9 Inflow Module Wiring

The inflow module is used to automatically record fuel being transferred into a tank as a delivery or between tanks, such as from a main tank to a day tank. The recording can be set to start when a specified flow occurs or when an external switch is operated. The settings for how the recording is started are in the flowmeter menu.



Unlike a pump this module does not require the use of a key or code to start recording

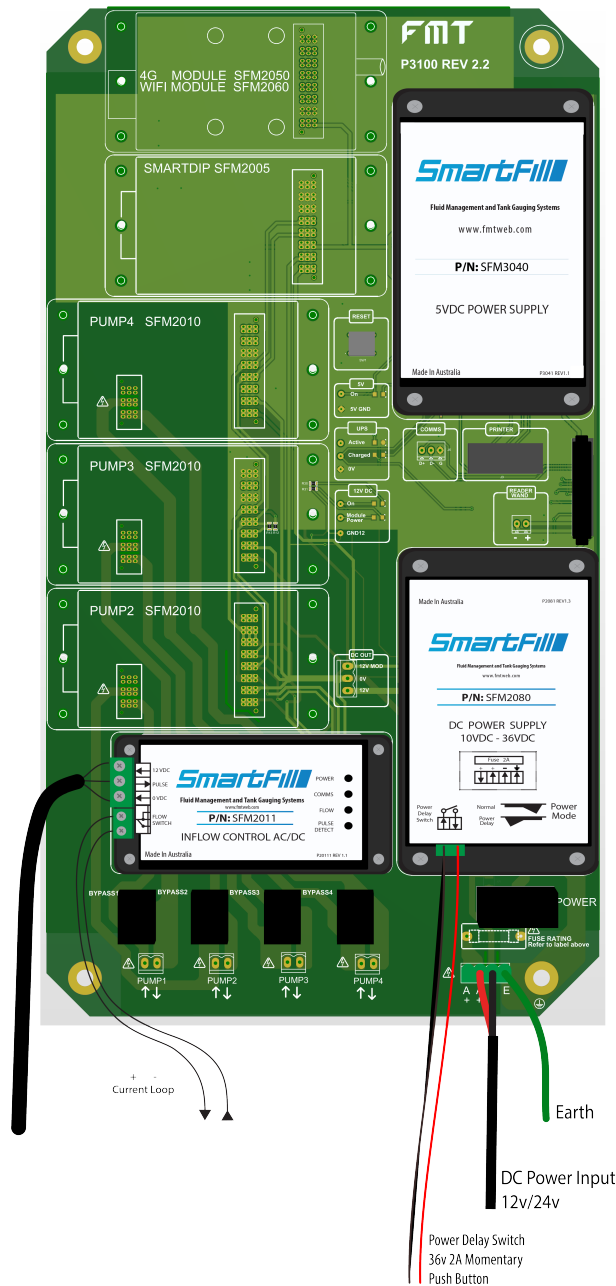

Figure 2.21: Wiring for InFlow Module

2.10 Communications Setup

The SmartFill GEN 3 is designed to automatically send data to a central website using either a direct Ethernet connection, 3G/4G or Wi-Fi. Ethernet is standard with all units and 3G/4G or Wi-Fi are optional modules that can be ordered with the unit or fitted later.

NOTE: Please follow instructions on separate setup sheet for Verizon Module setup and SIM requirements.

2.10.1 3G/4G Setup

The 3G/4G module is located in the upper left hand corner of the unit. To operate it needs to be fitted with a 3G/4G data SIM. The picture below shows how the SIM is fitted into the module:

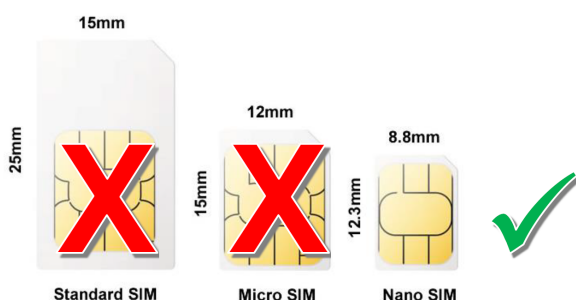

Figure 2.22: Installing SIM

2.10.1.1 Details for the 3G/4G SIM

The SmartFill GEN 3 module uses a 3G/4G SIM enabled for data to let data to be sent to your account. Below are the details of what is required for the SIM card:

- **Application Description:** A machine to machine application where data is automatically sent to a website
- **IoT SIM Cards** (Internet of Things) are the current evolution of **M2M** (machine to machine) data plans, which are specifically designed for this type of application. **NOTE:** You can use a data SIM with our unit, an IoT SIM is not required.
- **Data Capacity:** Minimum of 1GB per month.
- **SIM PIN:** The SIM card should be unlocked. The SIM PIN / PIN Code / SIM card security, should be disabled. This may be done when the card is supplied, but can also be set by fitting the card into a phone and using the phone settings menu to turn off this functionality
- **Physical Size:** To fit into the module the SIM must be a Nano SIM. **NOTE:** If you have an older unit with a 3G Communications module it may require the Standard SIM size.



SIM=Nano SIM

- **Service Provider/ Plan:** All service providers can provide a data SIM and plans vary between suppliers.
- **APN Configuration:** The unit is set to auto by default. If your cell provider requires a specific APN, you can set this in the SmartFill menu as follows:
 - Hold <CLR> and <ENT> until you see "Enter Installer or admin PIN"
 - Type in your admin or installer PIN (Usually 6789)
 - Press <9> for More
 - Press <2> for Network

- Press <1> for Access Point  Use the help option to understand how to use the text entry screen

Once the SIM is installed, you can view the status of the connection by holding down the "4" key, you can also press <ENT> from this screen to see more connection details. You can exit this screen by pressing the CLR key.

2.10.2 Wi-Fi Setup

To connect the SmartFill GEN 3 to your Wi-Fi network, the following guidelines must be obeyed:

- Your Wi-Fi router operates on the 2.4 GHz band and uses WPA security
- The SmartFill GEN 3 is no further than 40 metres from the Wi-Fi router
- There are no obstacles between the SmartFill GEN 3 and the Wi-Fi router
- The SmartFill GEN 3 Wi-Fi antenna is in the open in direct line of site to the Wi-Fi router

You will also need to input the SSID and password of the Wi-Fi network into the SmartFill GEN 3. To do this, do the following:

- Access the installation as per normal
 - Press and hold the <CLR> and <ENT> keys down together for a couple of seconds until the display reads "Enter admin or installer PIN"
 - Enter 6,7,8,9,ENT to open the installation menu
- Press <9> for More
- Then <2> for Network
- Press <3> for SSID. There are two ways to configure the SSID
 - Option <1> Select SSID.
The Select SSID screen allows you select which nearby Wi-Fi access point you would like to connect to instead of typing in the SSID manually. From this screen press <4> and <6> to scroll between the detected access points and press <ENT> to save the selected Access Point.
 - Option <2> Enter SSID.
If you have a hidden network or otherwise need to enter the SSID manually, this option lets you to enter the SSID. There are four rows of alpha-numeric characters that can be accessed by the 2 and 8 keys. To move left or right in a row, press 4 or 6. Pressing 5 adds the character that the selector is on.



Figure 2.23: Enter SSID Screen

- When complete press <ENT> to confirm.
- Press <4> to enter the Wi-Fi network password. (security for Wi-Fi is WPA)
- When complete press <ENT> to confirm.
- Then press <CLR> as many times as it takes to return to the default display.

The network status screen is accessed by pressing and holding the <4> key. It should read:

- Wi-Fi Network Status
- Link = Detected
- Network = Connected

- Internet = Connected
- Website = Connected
- Signal strength - if the signal strength reading is greater than -70dbm, connectivity issues may occur.

You can also press <**ENT**> from this screen to see additional connection details.

2.10.3 Ethernet

By default this is set to use DHCP and as long as your system is set for DHCP and has internet access the settings do not need to be changed.

If you require a static IP address you can set this in the network menu.

2.10.3.1 Enable Static IP Addressing:

To enable static IP addressing:

- Hold <CLR> and <ENT> until you see "Enter Installer or admin PIN"
- Type in your admin or installer PIN (Usually 6789) and press <ENT>
- Press <9> for More
- Press <2> for Network
- Press <5> for Dynamic Addressing, then press <5> to select "No"
- Press <ENT> to exit, you will then have option <6> Static Address

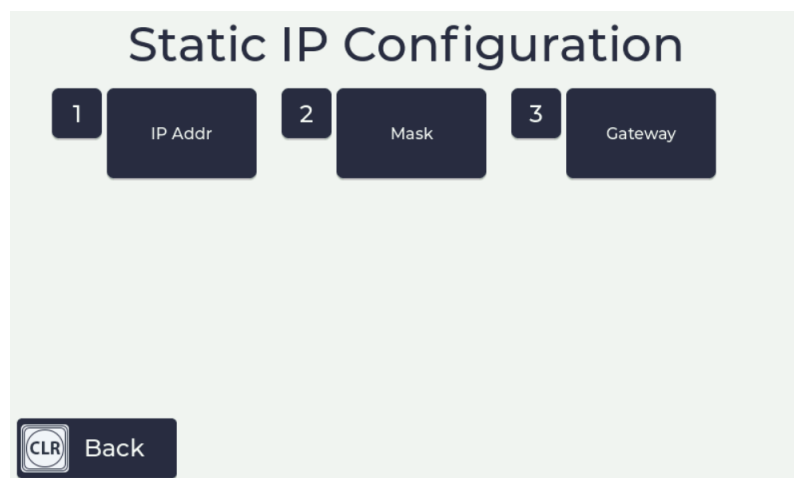

Figure 2.24: Static Address Menu

Option 6 will give 3 options:

1. **IP Addr**– enter the IP Address needed to connect to your network, ENT moves between fields
2. **Mask**– enter the Subnet Mask used by your network, ENT moves between fields
3. **Gateway**– enter the gateway IP Address of your network usually the router, ENT moves between fields

Once these have been set and you go back to the previous menu Option 7 will allow DNS to be set

1. **Primary DNS**– enter the IP Address of your or your ISPs DNS server to gain access to internet, ENT moves between fields
2. **Secondary DNS**– enter the IP Address of your or your ISPs secondary DNS server to gain access to internet, ENT moves between fields

Once all details have been entered press CLR as many times as needed to return to start screen and save settings.

2.11 MicroSD Card



Figure 2.25: MicroSD Card Slot on the Door Board

The SmartFill GEN 3 is fitted with a MicroSD card located on the door board of the unit. This MicroSD card is used for data-in-transit and persistent data storage. To remove the MicroSD card, gently press it down into the slot until a click is heard, then release the pressure so the card can slide out of the slot. To replace the MicroSD card, gently push the card into the slot until you hear a click. Then, release the card and it will slide into place.

If you need to replace it, the MicroSD card can be of a capacity up to 32GB and must be formatted to FAT32 before installing.

2.12 Using the System to Get Fuel

1. The driver touches an ID key (button) onto the sensor or swipes a card on the SmartFill GEN 3 unit or enters either a VIN (Vehicle Identification Number) or PIN (Personal Identification Number)
2. The SmartFill GEN 3 checks if the key is authorized. If the key is not authorized, the pump won't start, and the display will show Key Not Valid.
3. This system identifies whether a driver or vehicle key has been used. If a vehicle key has been used it, it may request the driver to enter a PIN, and/or an odometer reading depending on how the system has been configured.
4. If the following options are turned on
 - (a) The SmartFill GEN 3 requests the Odometer / hour meter reading. The driver enters this into the SmartFill GEN 3 keypad.
 - (b) The SmartFill GEN 3 requests the PIN number. The driver enters this into the keypad
 - (c) The SmartFill GEN 3 checks the pin number. If the pin number is not valid, the fuel pump won't start.
5. The driver fuels the vehicle. Once the fuel delivery is complete, the SmartFill GEN 3 stores the details. If the system is online, the transaction information is automatically sent to the appropriate account on the SmartFill website

2.13 Short Cut keys

The SmartFill GEN 3 has a series of short cut keys that allows easy access to commonly requested information. These are accessed by holding down the relevant key:

1. **CLR** - Displays the current tank levels if a SmartDip module is fitted and configured
2. **0** - Enables the entry of details regarding a fuel delivery
3. **4** - Displays the status of the network connection, which can be either 3G/4G, Wi-Fi or Ethernet
4. **5** - Displays the details of the most recent transactions
5. **6** - Displays the unit's model, serial number and current software version
6. **7** - Displays the last time the unit synchronised with the website
7. **9** - Displays the connection status if using AVID SmartTag readers

2.14 SmartFill Gen 3 Installation Menu

To access the Installation Menu, you will need to have a valid installer PIN. The default PIN is **6789**. To access the PIN entry screen, hold **CLR** and **ENT** simultaneously for 4 seconds, until the screen says "Enter Admin or Installer PIN".

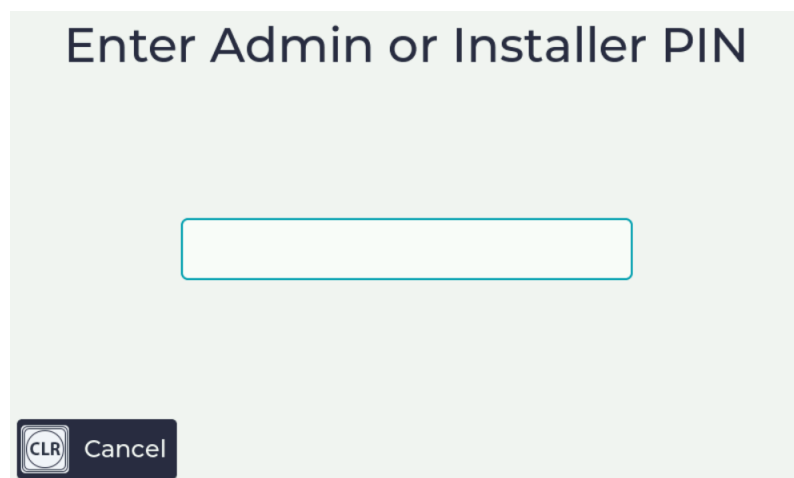

Figure 2.26: Enter Admin or Installer PIN Screen

Once your PIN has been accepted, you will be presented with the Installation Menu. Selections are made by pressing the number on the keypad corresponding to the desired menu item. **CLR** is used to go back, unless otherwise stated on-screen.



Figure 2.27: Installation Menu

2.14.1 Vehicles

This menu is used to manage keys and codes associated with vehicles.

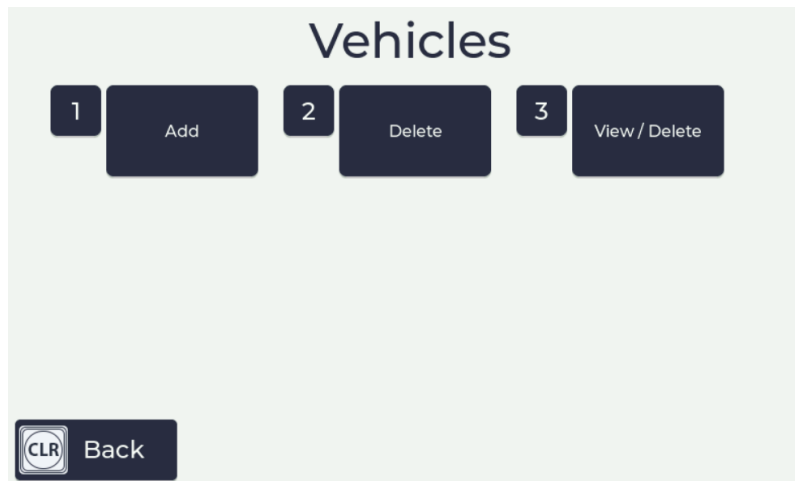

Figure 2.28: Vehicles Menu

1. **Add** - allows the user to add keys or codes to the SmartFill system. To add a key, the user must present the key for the system to recognise it. Codes are added by using the keypad.
2. **Delete** - allows the user to delete keys or codes from the SmartFill system. To delete a key, the user must present the key for the system to recognise it. Codes are deleted by using the keypad.
3. **View/Delete** - allows the user to view or delete keys from the SmartFill system. To delete keys, first make sure it's selected on the screen. Then, press <5> to delete. This will only delete the key from this unit, not others it may be associated with.

2.14.2 Plant

This menu is used to manage keys and codes associated with plant.

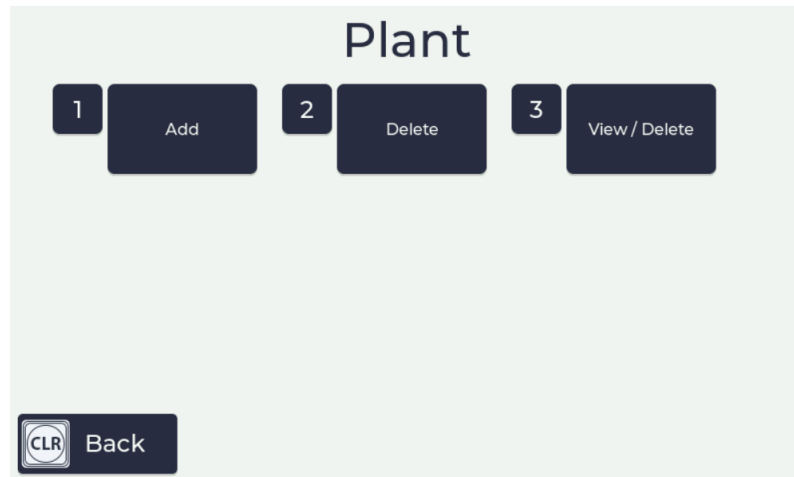

Figure 2.29: Plant Menu

1. **Add** - allows the user to add keys or codes to the SmartFill system. To add a key, the user must present the key for the system to recognise it. Codes are added by using the keypad.
2. **Delete** - allows the user to delete keys or codes from the SmartFill system. To delete a key, the user must present the key for the system to recognise it. Codes are deleted by using the keypad.
3. **View/Delete** - allows the user to view or delete keys from the SmartFill system. To delete keys, first make sure it's selected on the screen. Then, press <5> to delete. This will only delete the key from this unit, not others it may be associated with.

2.14.3 Drivers

This menu is used to manage keys and codes associated with drivers.



Figure 2.30: Drivers Menu

1. **Add** - allows the user to add keys or codes to the SmartFill system. To add a key, the user must present the key for the system to recognise it. Codes are added by using the keypad.
2. **Delete** - allows the user to delete keys or codes from the SmartFill system. To delete a key, the user must present the key for the system to recognise it. Codes are deleted by using the keypad.
3. **View/Delete** - allows the user to view or delete keys from the SmartFill system. To delete keys, first make sure it's selected on the screen. Then, press <5> to delete. This will only delete the key from this unit, not others it may be associated with.

2.14.4 Transactions

This menu is used to manage transactions and related settings such as presets, receipt numbers and transaction exports.

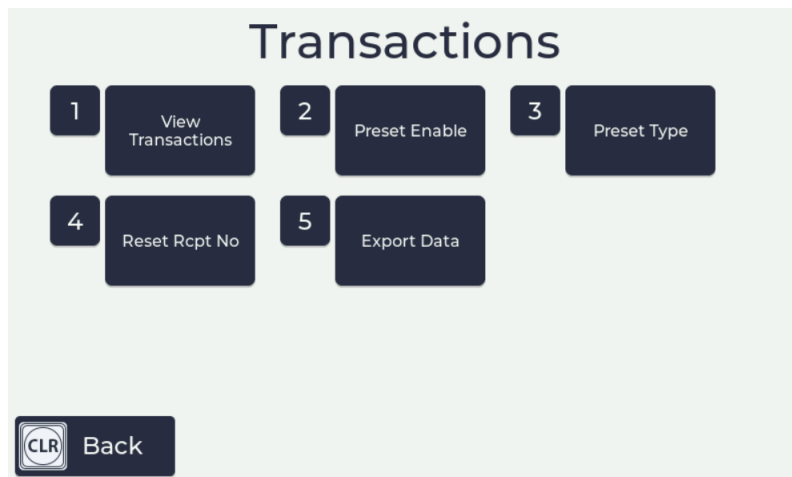

Figure 2.31: Transactions Menu

1. **View Transactions** - allows users to view all of the stored transactions at the SmartFill unit. Press the up arrow to view the next page, press the down arrow to view the previous page, and press **CLR** to exit back to the Transactions Menu.
2. **Preset Enable** - allows users to toggle the Preset requirement for transactions. When enabled, will require input of the desired quantity of fuel before dispensing and dispensing will stop at or before the assigned quantity each transaction.
3. **Preset Type** - allows user to select what value the preset input will be assigned. To select different options, use the up and down arrows. There are 3 options:

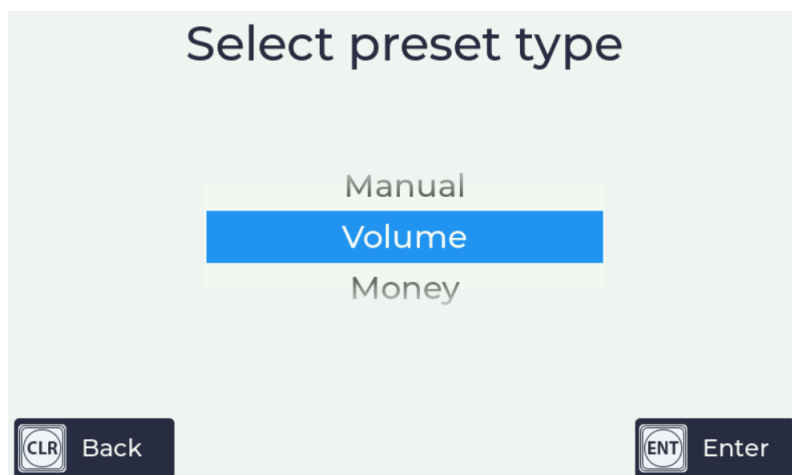

Figure 2.32: Selecting Preset Type

- (a) **Volume** - Preset input will be counted by the volumetric unit assigned (liters or gallons).
 - (b) **Money** - Preset input will be counted by the total cost of the fuel taken. Fuel price must be set for this to work.
 - (c) **Manual** - Preset input will be selected by a prompt at the time of each transaction.
4. **Reset Rcpt. Number** - If a receipt printer is being used with the SmartFill Gen 3, you can use this function to reset the receipt number to zero.
 5. **Export Data** - allows users to export all records of transactions to a USB for upload to their web portal via computer. This is useful for offline SmartFill units.

2.14.5 Unit

This menu is used to manage the SmartFill Gen 3 unit. This is where you can transfer data, restart the unit and clear all of the settings.

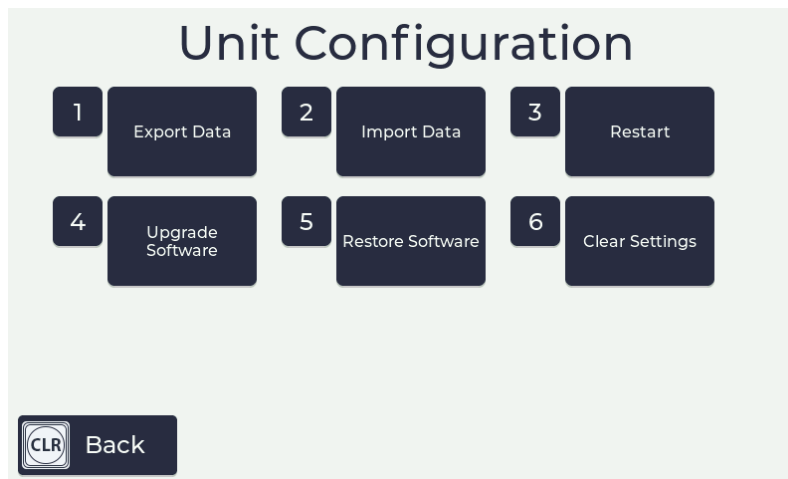

Figure 2.33: Unit Menu

1. **Export Data** - allows the user to export data to the web portal. Data exported includes transactions, drivers, assets and software logs.
2. **Import Data** - allows the user to import data from the web portal. Data imported includes transactions, drivers, assets, and software configuration.

WARNING



3. **Restart** - allows the user to trigger a restart of the SmartFill unit. Restarting the unit can take a few minutes to complete and you will not be able to dispense fuel until it's finished.
4. **Upgrade Software** - allows the user to upgrade the software version by downloading the software on their computer and taking it to the SmartFill unit via USB.
5. **Restore Software** - is used to restore the unit to the previous version of the SmartFill Gen 3 software that was installed before the last upgrade.
6. **Clear Settings** - allows user to clear data from the SmartFill unit. There are 2 options:

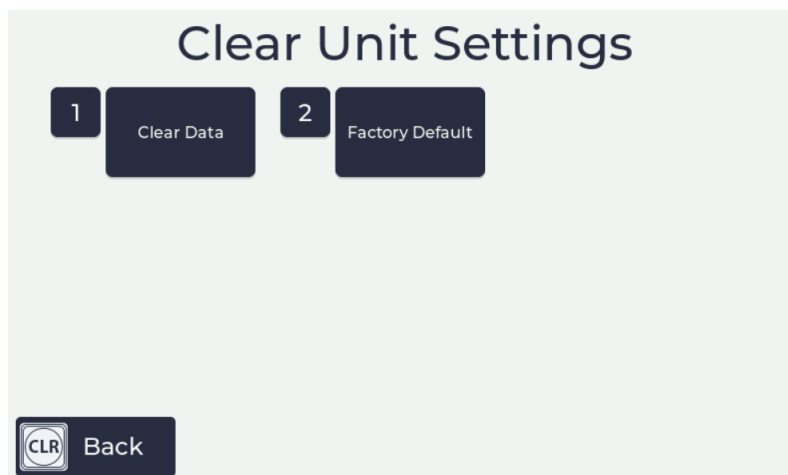

Figure 2.34: Clear Settings Menu

- (a) **Clear Data** - removes all keys, codes, transactions and assets from the SmartFill unit.
- (b) **Factory Default** - removes all keys, codes, transactions, assets and restores the configuration to the original factory settings.

2.14.6 Time & Date

This menu controls the time and date displayed on the home screen of the SmartFill Gen 3.

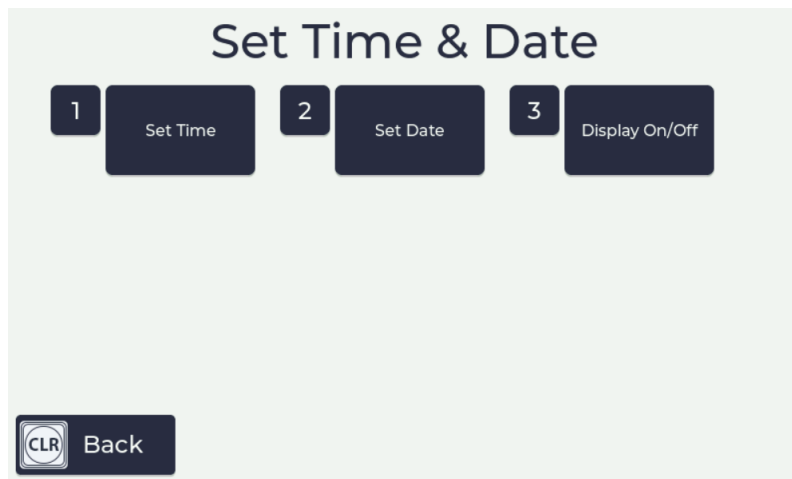

Figure 2.35: Time & Date Menu

1. **Set Time** - allows users to set the current system time. Digits are entered using the keypad. **CLR** will delete digits and **ENT** will save the time.
2. **Set Date** - allows users to set the current system date. Digits are entered using the keypad. **CLR** will delete digits and **ENT** will save the date.
3. **Display On/Off** - allows users to select whether the time and date are displayed on the SmartFill Gen 3 home page or hidden.

2.14.7 Tanks

This menu is used to configure tanks. This will only be visible if you have a SmartDip or ATG module connected to your SmartFill unit.

2.14.7.1 Tanks

The Tank Gauging Settings menu has 3 options:

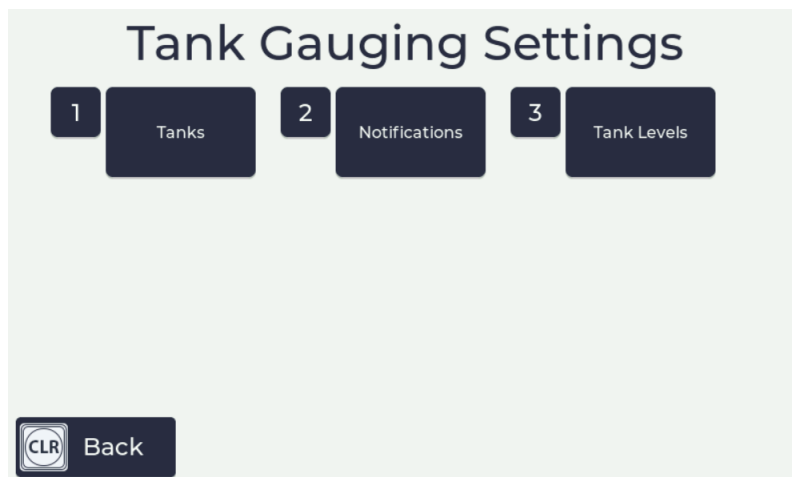

Figure 2.36: Tank Gauging Settings Menu

Notification Settings - selecting Notification Settings from the Tanks menu will allow you to set up notifications for your tank levels. Users can set a designated time and mobile number to receive SMS alerts. (Only using 3G/4G modules with a text-enabled SIM card).

Tank Levels - allows users to see an on-screen tank level and gauge.

Tanks - Selecting Tanks from this menu will allow you to select which of the tanks configured you would like to adjust the settings for. Select the number of your tank to progress to the next page and see the following options:



Figure 2.37: Tank 1



1. **Enable Tank** - allows user to enable/disable the selected tank.
2. **Type** - allows user to set the shape of the tank. The options are rectangle, horizontal cylinder, vertical cylinder or 20-point dips.
3. **Dimensions** - allows user to enter the height, width or diameter of the tank; depending on the type of tank selected.
4. **Density** - allows the user to set the density of the fluid in the tank. Diesel and Petroleum are preset quantities, or you can enter a custom quantity.  AdBlue is 1088.
5. **Sensor Range** - allows the user to set the range of the tank sensor using the preset sensor heights or a custom input field.
6. **Calibration** - allows the user to calibrate the tank sensor by entering a manual dip. SmartFill will then calculate the sensor offset.  Sensor offset should be +50 +/-20mm. A negative offset means something has been configured or installed incorrectly and should be investigated.

Figure 2.38: //Calibration Menu

7. **Alarm** - allows users to enable/disable and set up high or low alarms. These alarms will alert user if the tank level goes higher than the high range setting or below the low range setting.
8. **Import Settings** - allows users to import settings via USB from the web portal.
9. **Information** - allows users to view information about the tank; including 20-point dip values, capacity and values saved when setting up the tank.

2.14.8 Pumps/Flowmeters

This menu allows you to configure the pumps and/or flowmeters connected to the SmartFill. You can access the settings by entering this menu, then choosing the Pump you wish to configure.

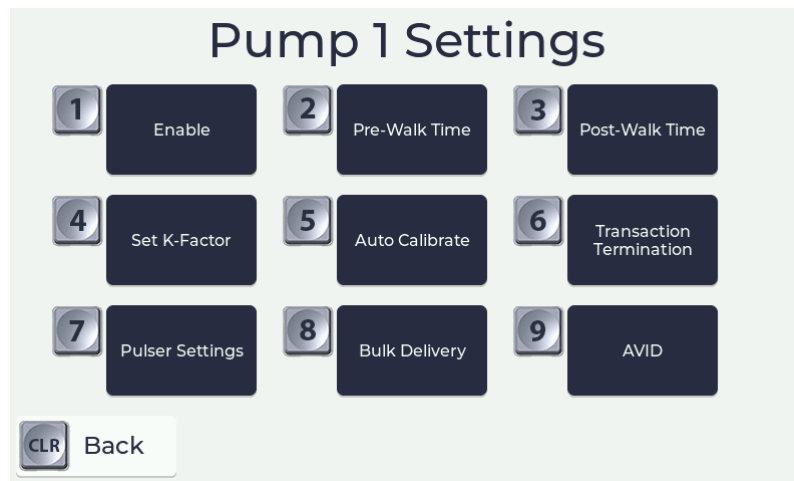

Figure 2.39: Pumps/Flowmeters Menu

1. **Enable** - allows users to enable/disable the selected pump.
2. **Pre-Walk Time** - allows users to set the waiting period between authorizing the pump, and fuel dispensing.
3. **Post-Walk Time** - allows users to set the waiting period between the last flow detected from the pump and the transaction ending.
4. **Set K-Factor** - allows users to configure the pulse/L and change the result into the K-Factor to accurately track and record flow quantities.
5. **Auto Calibrate** - allows users to use a proving measure of a known volume to dispense fuel in order to automatically calculate and calibrate the K-Factor.
6. **Transaction Termination** - allows users to select whether a transaction will be terminated by Walk-Time or Nozzle Switch (hanging up the nozzle).
7. **Pulser Settings** - allows users to configure the pulser/flowmeter:

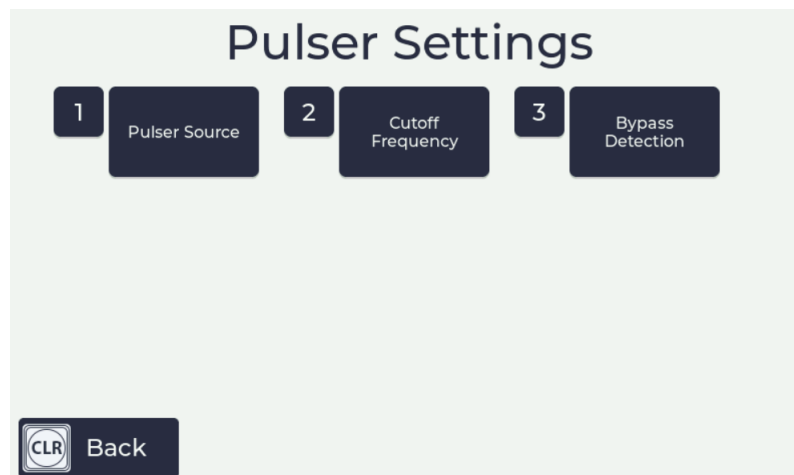

Figure 2.40: Pulser Settings Menu

- (a) **Pulser Source** - allows users to select from which module the pump will obtain the pulser input.
 - (b) **Cutoff Frequency** - sets the frequency in Hz at which the module will no longer respond to pulses. This is used to stop the module responding to low-frequency vibration in the flowmeter. 1 is default, passing all signals.
 - (c) **Bypass Detection** - allows the recording of flow to be counted and reported as an unauthorized transaction.
8. **Bulk Delivery** - allows users to configure their pump for bulk deliveries. When starting a bulk fuel delivery, a preset quantity must be entered. This is called the delivery volume.

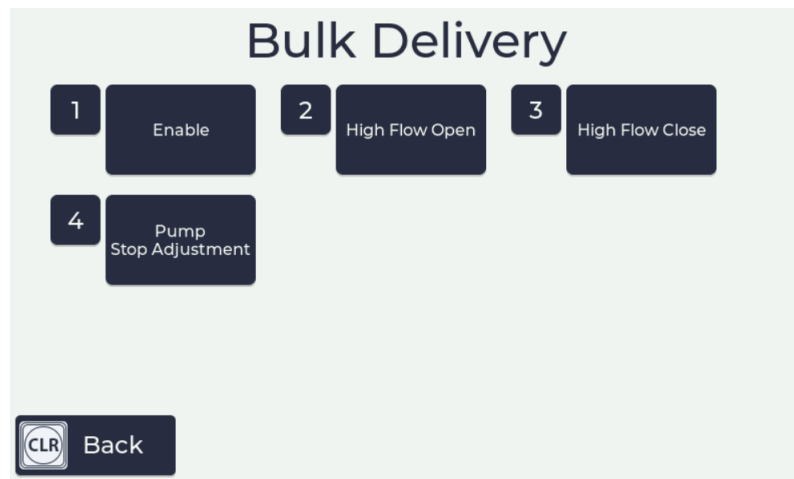

Figure 2.41: Bulk Delivery Menu

- (a) **Enable** - set whether to enable or disable bulk delivery. If enabled, Pump 2 will be disabled as it's being used in conjunction with Pump 1 to control bulk fuel delivery.
- (b) **High Flow Open** - set the volume dispensed at which the high flow valve will open.
- (c) **High Flow Close** - set the offset of the volume dispensed at which the high flow valve will close.
- (d) **Pump Stop Adjustment** - sets the offset to stop the pump below the preset limit to stop overflow.

2.14.9 More

Select More to see more options.

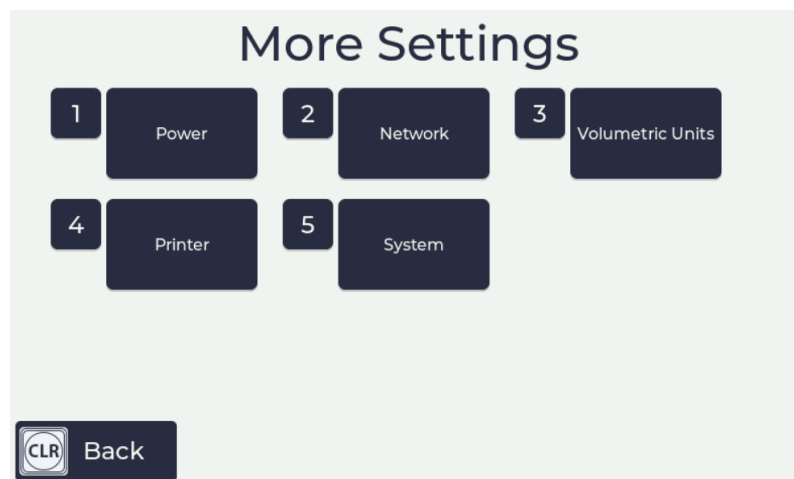

Figure 2.42: More Settings Page

2.14.10 Power

This menu allows users to configure the power settings for the SmartFill Gen 3 by enabling the system to turn off automatically after a sync or a delay period.

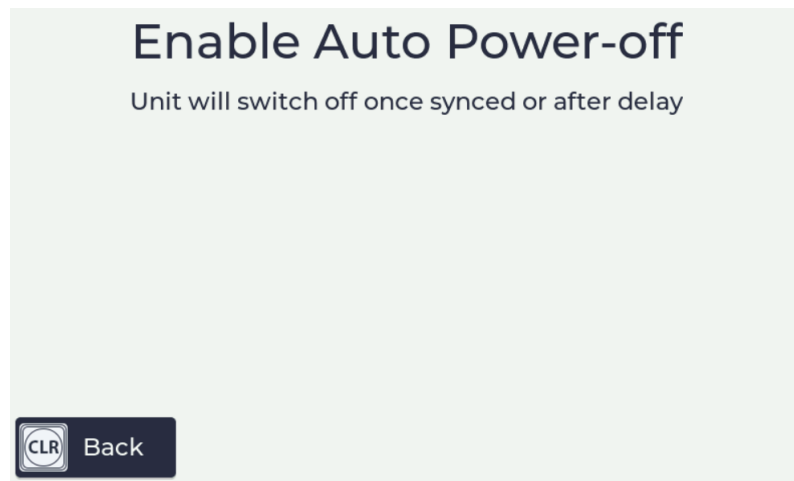

Figure 2.43: Power Settings

2.14.11 Network

The network menu allows you to configure your Ethernet, 3G/4G or Wi-Fi connections. The options displayed will vary between connection types.

2.14.11.1 Ethernet

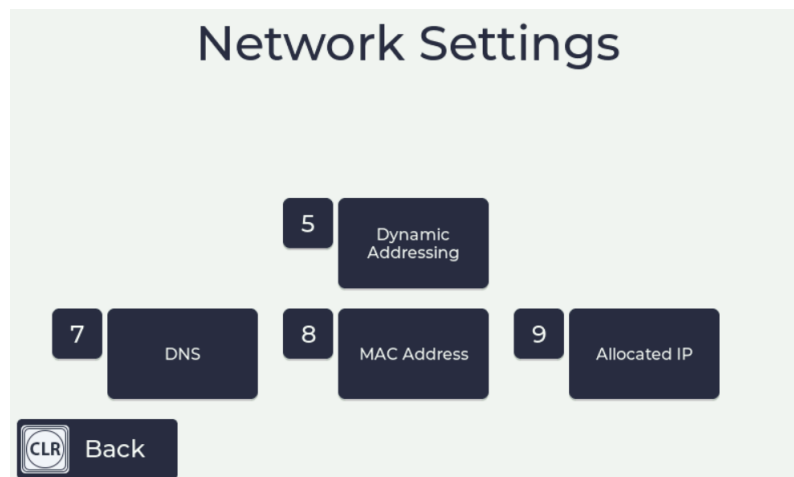

Figure 2.44: Ethernet Network Settings

1. **Dynamic Addressing** - allows the user to enable dynamic addressing with DHCP. This is enabled by default.
2. **DNS** - allows user to set the primary and secondary domain name server addresses.
3. **MAC Address** - allows the user to see the media access control address of the SmartFill unit.
4. **Allocated IP** - allows user to view the current DHCP status, IP address, subnet mask and gateway address.

2.14.11.2 Wi-Fi

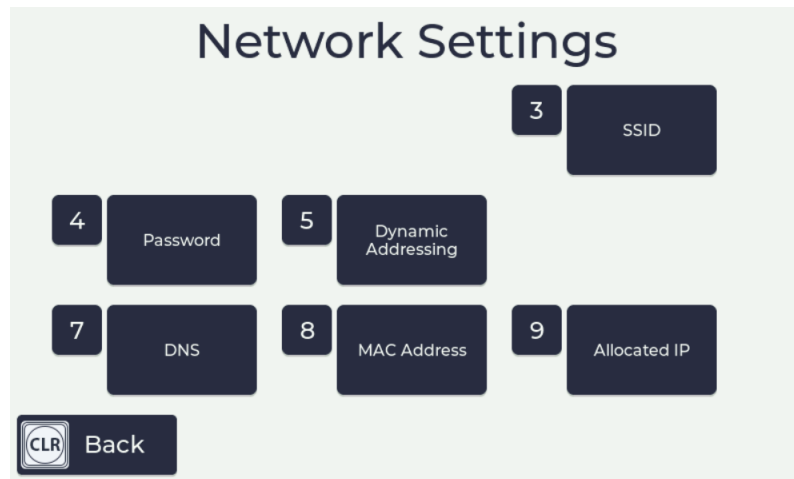

Figure 2.45: Wi-Fi Network Settings

1. **SSID** - allows user to enter the name of your wireless network.
2. **Password** - allows user to enter the password for your wireless network.
3. **Dynamic Addressing** - allows the user to enable dynamic addressing with DHCP. This is enabled by default.
4. **DNS** - allows user to set the primary and secondary domain name server addresses.
5. **MAC Address** - allows the user to see the media access control address of the SmartFill unit.
6. **Allocated IP** - allows user to view the current DHCP status, IP address, subnet mask and gateway address.

2.14.11.3 Cellular

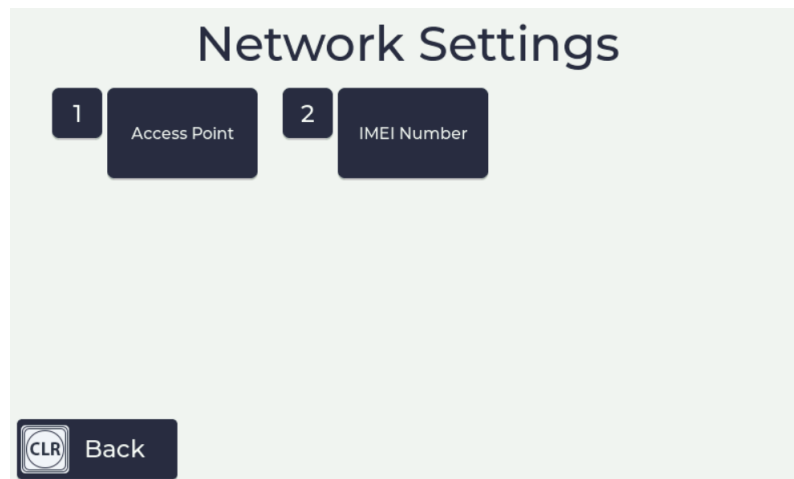

Figure 2.46: Cellular Network Settings

1. **Access Point** - allows user to enter the Access Point Network (APN) provided by their internet service provider.
2. **IMEI Number** - IMEI number is a unique identifying number for the SmartFill 3G/4G module in use.

2.14.12 Volumetric Units

A volumetric unit is a unit of measurement for measuring volume or capacity. There are 3 options of unit to select from in SmartFill Gen 3 (Imperial Gallon, US Gallon and liters) and you can select the required unit using the up and down arrows.

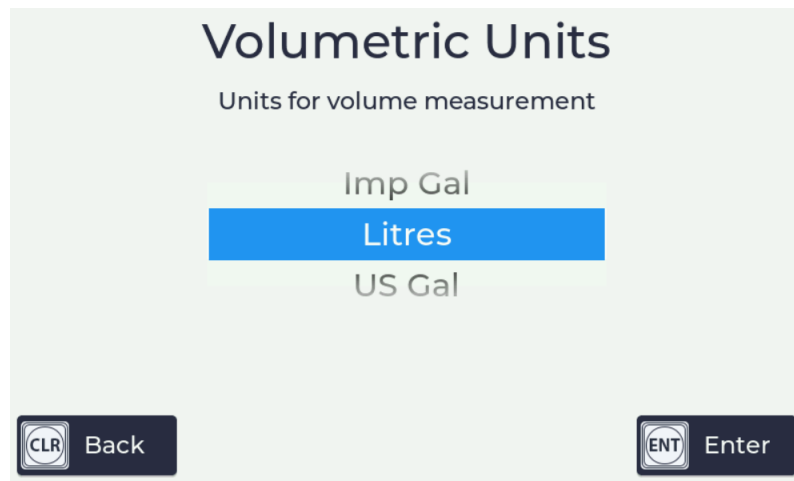

Figure 2.47: Volumetric Units Menu

2.14.13 Printer

SmartFill Gen 3 can use a serial (RS232) printer that uses the standard ESC/POS protocol, so if the printer support this, it should work with SmartFill Gen 3.

serial connection uses GND, TXD and RXD, at the specified comms settings (default 9600,8,N,1, but can be set at the SmartFill Unit).

The printer menu allows users to set different configuration settings for the use of a printer, and print a test page.

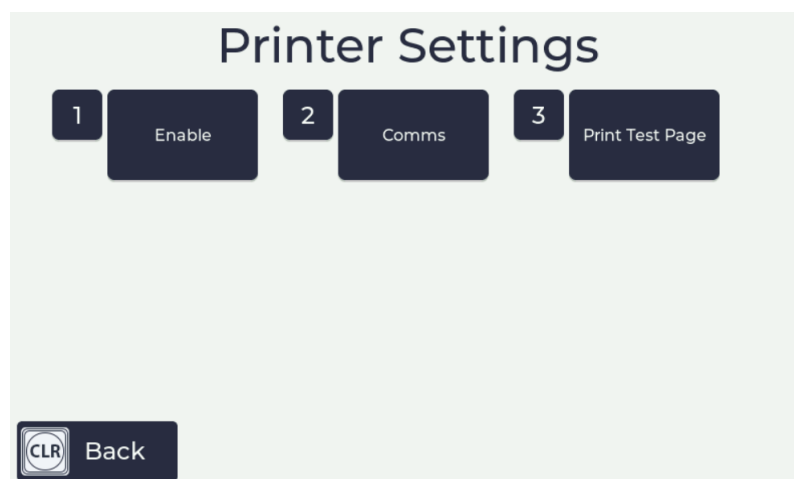

Figure 2.48: Printer Menu

1. **Enable** - allows the user to enable or disable the printer by selecting “Yes” or “No”.
2. **Comms** - allows the user to change comms settings related to the use of a printer.
3. **Print Test Page** - allows the user to print a test page to ensure the printer is working correctly.

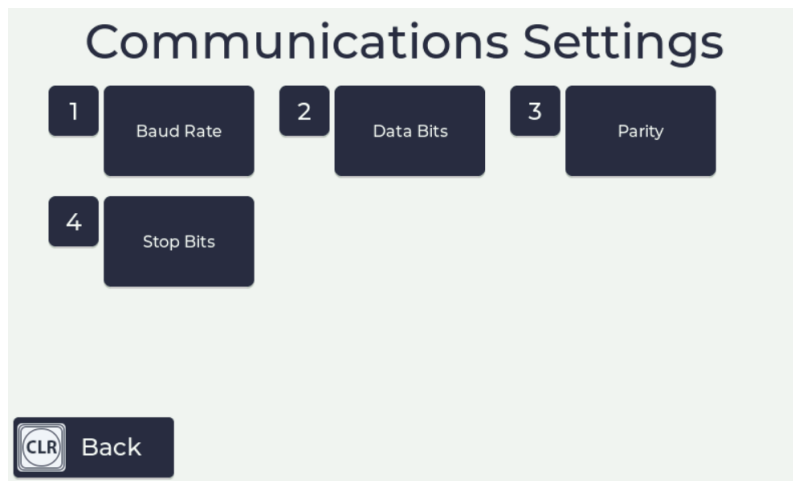

Figure 2.49: Printer Comms Menu

2.14.13.1 Printer Communications Settings

1. **Baud Rate** - The baud rate specifies how fast data is sent over a serial line. It's usually expressed in units of bits-per-second (bps). The default baud rate is 9600.
2. **Data Bits** - The data bits transferred through a serial port might represent device commands, sensor readings, error messages, and so on. The default value is 8 for binary signals.
3. **Parity** - Parity is a simple way to error-check. Parity is either Even, Odd, or None. Default value is None.
4. **Stop Bits** - The RS232 stop bit merely gives a period of time before the next start bit can be transmitted. Default is 1 bit.

2.14.14 System Information

The System Information menu is used to access different information about the SmartFill unit. Each sub-menu has a specific set of data for viewing.

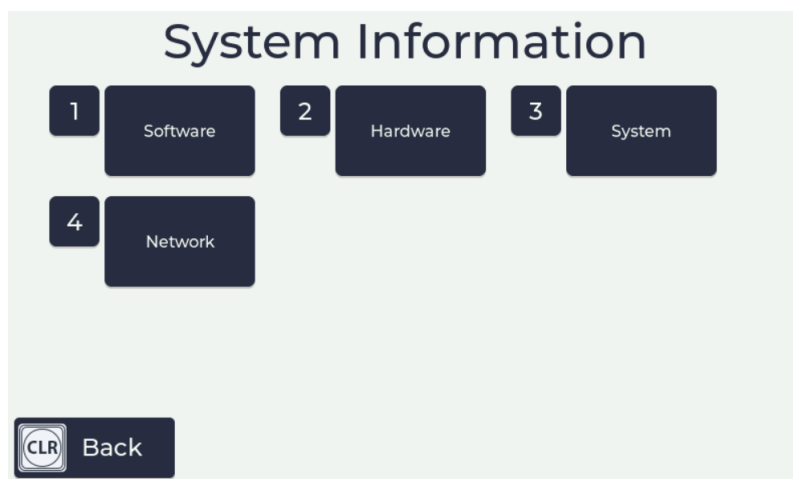

Figure 2.50: System Information Menu

1. **Software** - allows users to view the software versions for the Main Processor (MP) and Peripheral Processor (PP).
2. **Hardware** - allows users to view the number of detected pumps and flowmeters. Also shows the network connection type.
3. **System** - allows users to view the serial number and model number of the unit, also the MP version and PP version of the software.
4. **Network** - allows users to view the network connection type and IP address of the SmartFill Gen 3 unit.

Chapter 3

Configuring and Using Website Page

The SmartFill Gen 3 website is used to store all transactional data from the units, configuration information for the unit and data that is associated with transactions, such as a drivers name or the department to which the vehicle belongs:

The website is located at www.fmtdata.com

3.0.1 Creating Your Website and Adding Your First Unit

To set up your website and add a unit for the first time, use your web browser to navigate to www.fmtdata.com/new Once you arrive at this page, select whether you have an existing account on the fmtdata website, if you don't have an existing account, click on **"No"** and then enter the serial number and code provided with the unit. A copy of this information is contained on the USB drive supplied with the unit and a hard copy is supplied with the unit.

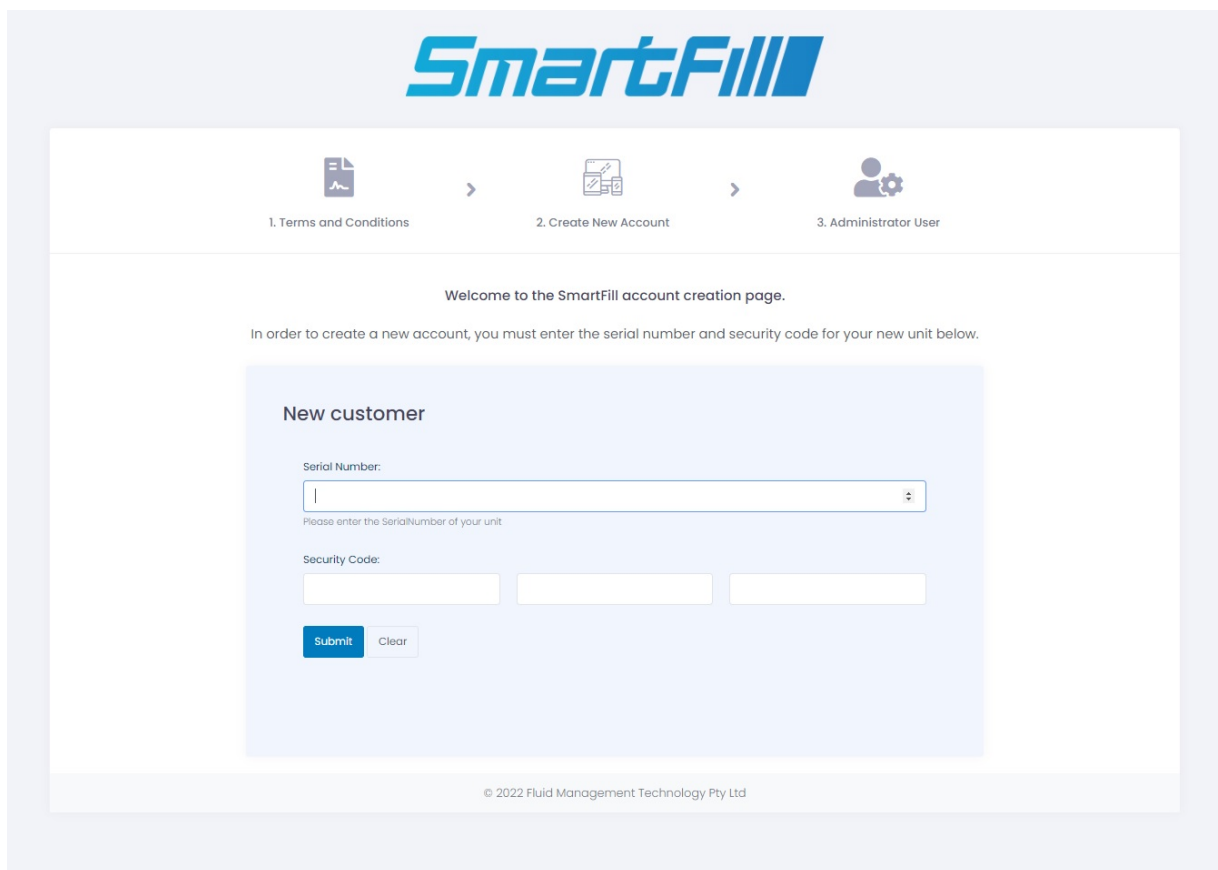
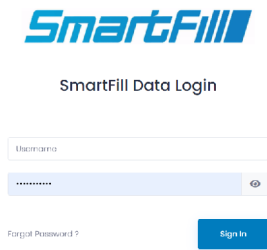

Figure 3.1: Initial Account Activation Page

Once you do this you will be asked to fill in some company details and create an Admin user name and password. Unless you change them, these are credentials you will use from now on to log on to the your website. Once you have completed this step you will be taken to the first page of your website.

3.0.2 Logging In Once the Website is Created

Once you have created your website you can log in using the credentials you created in 3.0.1 at www.fmtdata.com



3.0.3 Dashboards

This feature requires a subscription to our Pro Monthly Reports website add-on.

From here, you can create custom dashboards to view details about total transactions, fuel consumed, total vehicles, daily fuel usage and more.

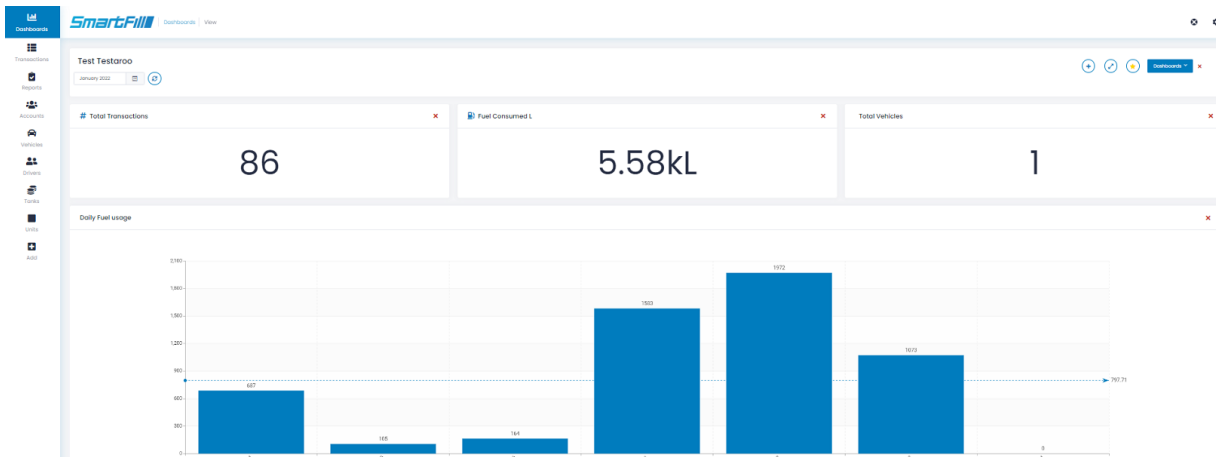

Figure 3.2: Dashboard Page

3.0.4 Transactions Page

The transactions page is the first one that shows when you log on if you are not subscribed to Pro Reports. It displays transactions in the selected date range that have been transferred to the website from all associated units. You can select the required date range from the drop-down menu at the top of the screen

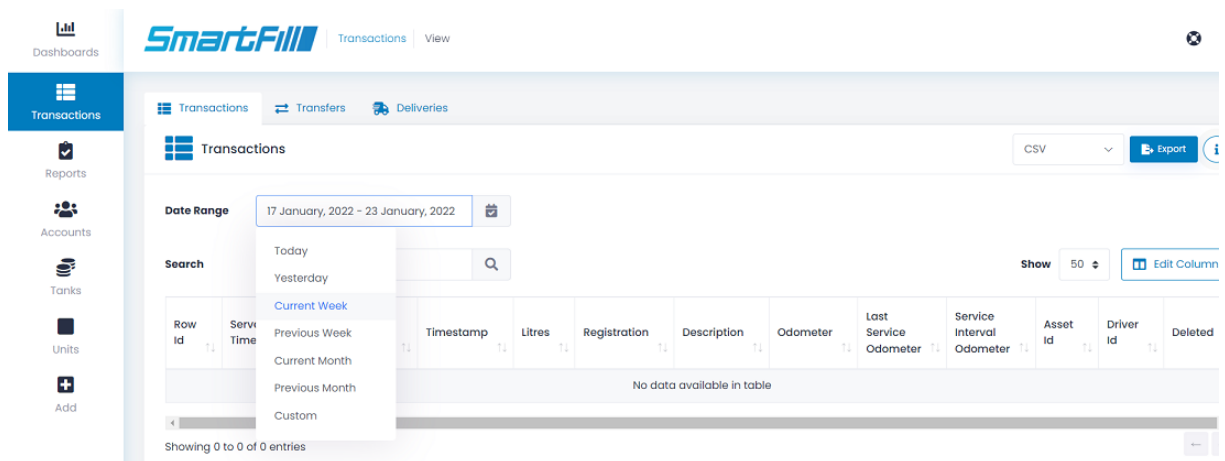

Figure 3.3: Website Transaction Page

3.0.4.1 Transactions

Displays the main transaction screen. From here you have the following options:

1. **Date Range** - From drop down menu you select what date range you want to display and export. If you want a custom date range then select custom and click on the "From" and "To" dates to set them to the dates required.
2. **Export** - Exports all transactions in the date range to a .csv, .xls, or .xlsx file that can be viewed in a spreadsheet program (e.g. Microsoft Excel)



3. **Show** - selects how many rows will be shown at a time. Select to show 50 rows per page to enable the webpage to open quicker. The more rows it has to show the longer it will take to load. When you export the transactions it will still export all the transactions in the date range.
4. **Transfers** - Displays fuel transfers between tanks for a set date range.
5. **Deliveries** - Shows fuel deliveries made, manual and automatic in a chart and list format.

3.0.4.2 Transactions - Edit Columns

If you select Edit Columns on the transactions page you will be presented with the transaction page configuration page. This page enables you to select which columns are displayed and the order they show in. At the top of the page are the selected columns. You can change the column headings by selecting the heading name and then over typing it with the new name. Headings that are greyed out are set in one of the other configuration screens. You can select which columns are displayed by dragging and dropping those required into the top section or by clicking the + symbol. The columns are removed by dragging them into the bottom section or clicking the red X.

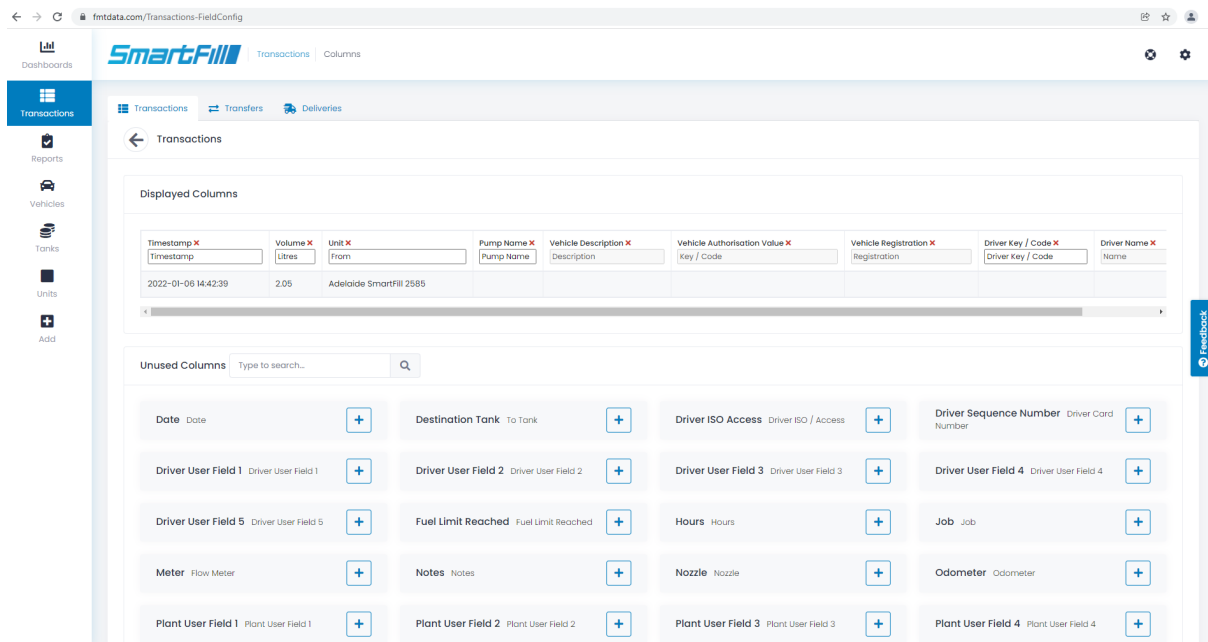

Figure 3.4: Configuring the Transactions Page

3.0.5 Reports

The Reports page can only be accessed while the account is subscribed to PRO Reports.

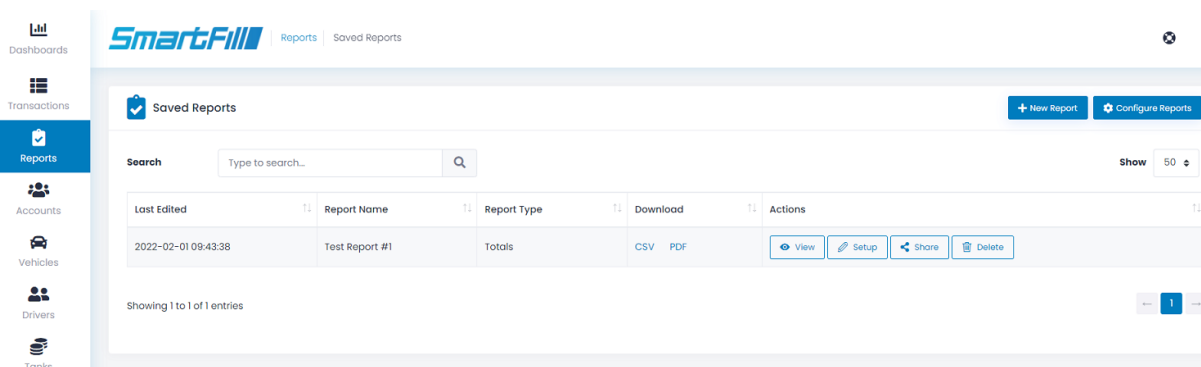

Figure 3.5: Reports Page

Use these to select desired report settings.

Search - Use this field to search for reports by typing in a keyword related to the report you're searching for.

Show - Use this drop box to select how many reports you would like to see per screen. The default is 50.

Download - select one of the displayed formats to download the saved report.

Actions - View, Setup (Edit), Share or Delete a saved report.

3.0.5.1 New Report

Click **New Report** to generate a new report. The report generated can either be viewed as a one-off, or saved for later use. Saved reports can be viewed from the Reports page. (Fig. 19)

There are 7 reports you can create. Each type is designed to give you specific information.

Totals - Shows accumulated fuel totals per vehicle, per driver or by other data points available.

Reconciliation - The reconciliation report will compare the sum of all deliveries and transactions using the starting and ending dips for the time period specified.

Service - Service report will list all vehicles that are due, overdue or coming up for a scheduled service. Requires vehicle/plant to have odo/hours enable and columns configured with service interval and last service fields populated with valid data.

Consumption - Shows the fuel consumption of each vehicle based on fuel taken and odometer readings. Must have odo/hours enabled to calculate the consumption.

Trip Consumption - Shows the fuel consumption per trip for each vehicle based on fuel taken and odometer readings. Must have odo/hours enabled to calculate the consumption.

Transactions - Shows the transactions made on your SmartFill unit(s). You can filter the data to output the results you need.

Deliveries - Shows the fuel deliveries received within a period of time. You can apply filters to this report to output the desired data.

3.0.5.2 Configure Reports

Click configure reports to change the settings related to the report outputs.

Page Size - Select the page size that the report will be printed on when using .pdf reports. The options are A4, A3, US Letter or US Ledger.

Page Orientation - Select whether the report will be printed vertically or horizontally on the .pdf report.

End Page - Set whether an “End of Document” page is added to the end of every report.

Account Currency - Sets the currency used to calculate prices (if enabled).

3.0.6 Accounts

Accounts are a way for you to identify specified vehicles and apply a discount/mark up depending on your preference. You can associate an account with a vehicle to ensure transactions are linked to the correct account.

The accounts page displays all created accounts and allows you to delete from the Accounts page.

Account Name	Custom Pricing	Pricing Options	Discount/Mark Up	Actions
test1	Discount	Percentage	22	View Delete
test2	Markup	Cents/L	55	View Delete

Figure 3.6: Accounts Page

3.0.6.1 Accounts - Add New Account

Click Add New Account to create an account to be displayed on the accounts page and configured for custom pricing or discounts.

3.0.6.2 Accounts - View

Once you have create an account, click “View” from the Accounts page to add a vehicle key or code to be associated with this account.

3.0.6.3 Accounts - Delete

Delete an account by pressing delete on the Accounts page. The website will ask you to confirm the procedure. No associated customers will be deleted by pressing this, only the account.

3.0.7 Vehicles

Details for vehicles, such as which key or code (PIN or VIN) is used to identify the equipment and description are set up by clicking on “Add”, then the vehicles page or the buttons on the side toolbar if you have vehicles set up.

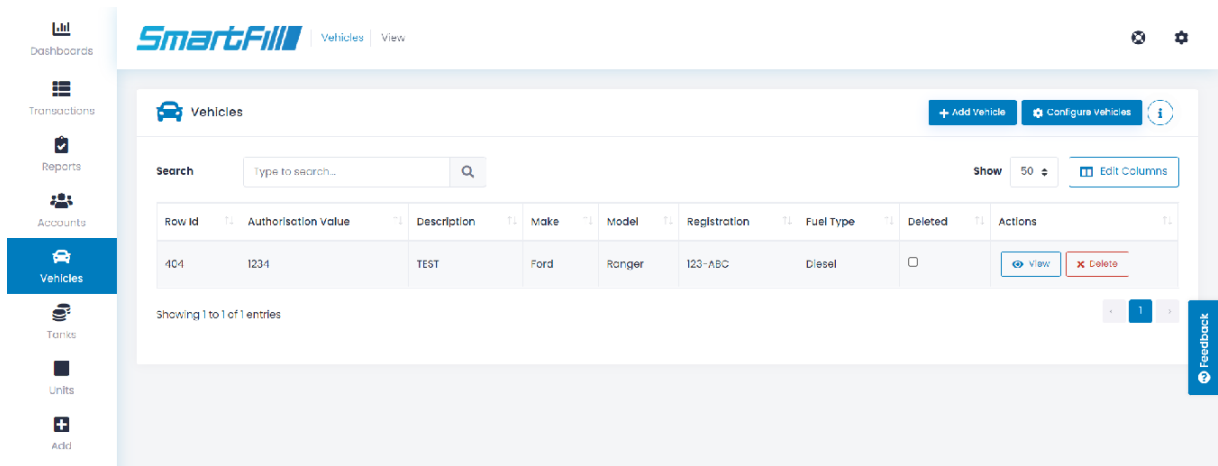

Figure 3.7: Vehicles Page

3.0.7.1 Add Vehicle

Use this to add a new key or code. You will be prompted to enter data for all the columns you currently have selected for display e.g make, model, registration number.

If you are using swipe cards then you will need to add the ISO/Access pair name as well as the card number. The ISO/Access pair should be added first. See ??

3.0.7.2 View

The main page provides a overview of existing vehicles and the details that have been associated with them. Details of the key or code are automatically transferred to all selected units. In addition for vehicles the description and registration details are automatically transferred to all selected, connected units.

Details for existing vehicles can be changed by selecting a cell, such as description and over typing the existing text. Vehicles can be disabled by deleting them in the unit or selecting the delete button next to key or code on the website

Note: If a vehicle is deleted from the website then it cannot be re-added directly at the unit.

3.0.7.3 Edit Columns

If you select Edit Columns on the vehicles page, you will be presented with the columns configuration page. This page enables you to select which columns are displayed and the order they show in. At the top of the page are the selected columns. You can change the column headings by selecting the heading name and then over typing it with the new name. Headings that are greyed out are set in one of the other configuration screens. You can select which columns are displayed by dragging and dropping those required into the top section or by clicking the + symbol. The columns are removed by dragging them into the bottom section or clicking the red X.

3.0.7.4 Configure Vehicles

Unit Allocation Accessed by clicking "Configure Vehicles", allows keys to be allocated to specific units that report to this website. The default settings is keys/codes are allocated to all units

Transaction Input Accessed by clicking "Configure Vehicles", use this to select what inputs are requested on a per vehicle basis. The options are:

1. Enable Odometer - driver must enter odometer when refuelling the vehicle or piece of plant associated with the key or code
2. Enable Hourmeter - driver must enter hourmeter when refuelling the vehicle or piece of plant associated with the key or code
3. Enable Job Input - driver must enter a job number when refuelling the vehicle or piece of plant associated with the key or code
4. Enable User Data Input - driver must enter User Data when refuelling the vehicle or piece of plant associated with the key or code

Time of Day Access Accessed by clicking "Configure Vehicles", used to set during what periods of time a specific key/code associated with a vehicle or piece of plant can access fuel. Use Edit Time of Day List button to edit existing time of day configurations or add new ones.

Time-of-day Access

How to ► Allow weekly access to use SmartFill Units.

Batch Actions

TOD Access:
Default

Search: Type to search... [Q] Show: 50

NaturalValue	Registration	Description	Time-of-day Access	Enable Time-of-day Access
1234	123-ABC	TEST		<input type="checkbox"/>

Showing 1 to 1 of 1 entries

Figure 3.8: Time of Day Setup

Fill Limits Accessed by clicking “Configure Vehicles”, sets a fill fuel limit for a specific key/code associated with a vehicle or piece of plant. This prohibits more than the specified quantity of fuel being dispensed into a given vehicle or piece of plant on a given transaction. To change the limit click in the “Allocation per Fill” field and either enter the value or over type an existing value.

Daily Allocation Accessed by clicking “Configure Vehicles”,sets a total daily allocation of fuel for a specific key/code associated with a vehicle or piece of plant. If this feature is used the daily limit must be more than the fill limit or the vehicle will be unable to be filled to specified limit. The two settings interact and the lower of the two will determine how much fuel can be taken.

3.0.8 Drivers

Driver details are set up on the Drivers page. The name of the driver can be associated with a key or code and when this is used the driver name will be shown in the transaction as long as name has been chosen as one of the displayed fields in the transactions columns page.

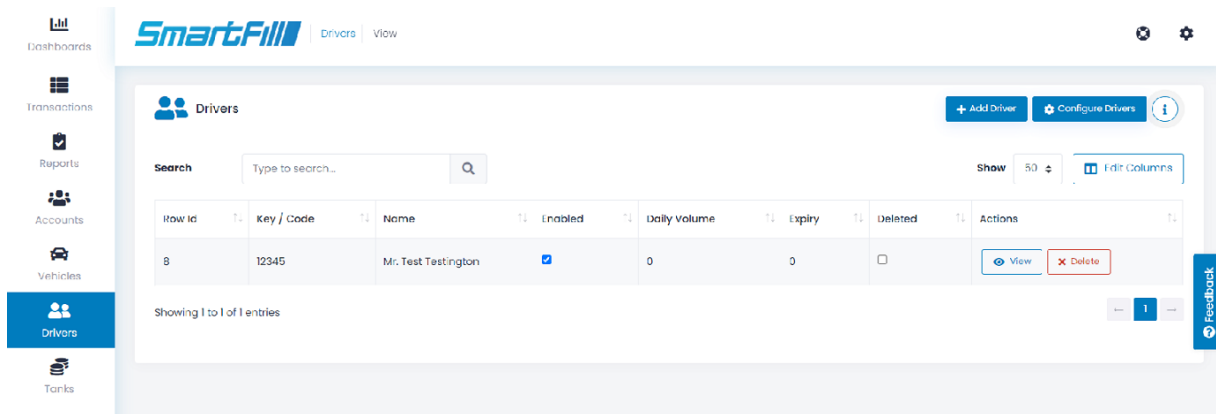

Figure 3.9: Drivers Page

3.0.8.1 Add Driver

The add driver button allows you to add a new driver. You will be prompted to enter data for each of the columns that are displayed on the drivers page. On the input type you must select whether the entry is a key or a code (PIN/VIN). Once a driver is added you can edit it from the drivers page by selecting and over typing the entry.

If you are using swipe cards then you will need to add the ISO/Access pair name as well as the card number. The ISO/Access pair should be added first. See ??

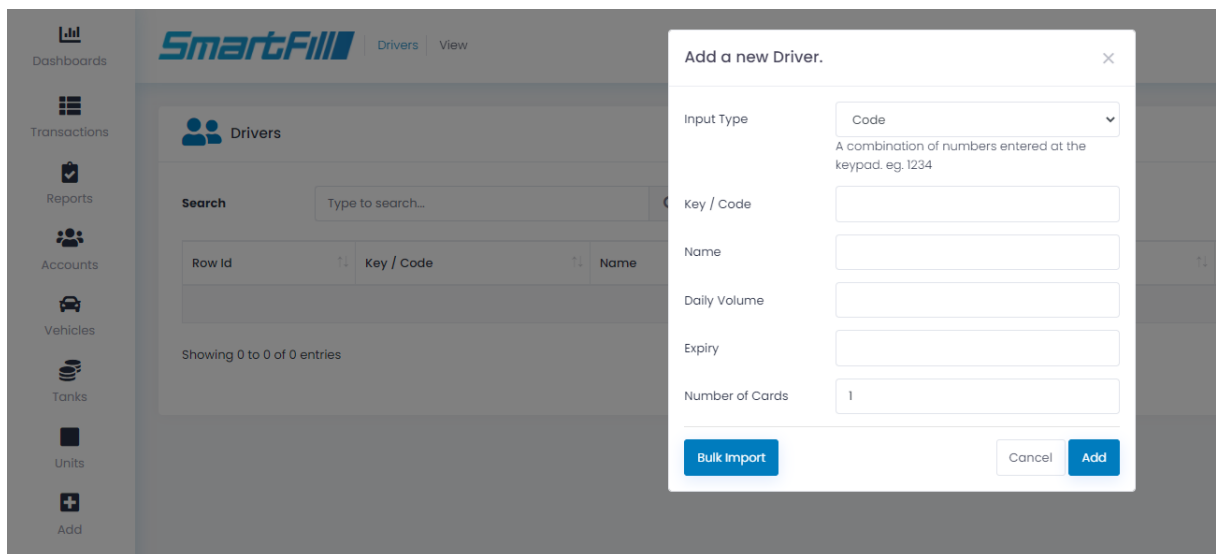

Figure 3.10: Add Driver Page

3.0.8.2 Drivers - View

The main page provides a overview of existing codes or keys and the names that have been associated with them. Details of the key or code are automatically transferred to all selected units. In addition the driver names are automatically transferred to all selected, connected units.

Details for existing drivers can be changed by selecting a cell, such as description and over typing the existing text. Drivers can be disabled by deleting them in the unit or selecting the delete button next to key or code on the website

3.0.8.3 Drivers - Edit Columns

If you select Edit Columns on the Driver pages you will be presented with the columns configuration page. This page enables you to select which columns are displayed and the order they show in. At the top of the page are the selected columns. You can change the column headings by selecting the heading name and then over typing it with the new name. Headings that are greyed out are set in one of the other configuration screens. You can select which columns are displayed by dragging and dropping those required into the top section or by clicking the + symbol. The columns are removed by dragging them into the bottom section or clicking the red X.

3.0.8.4 Configure Drivers

Unit Allocation Accessed by clicking “Configure Drivers”, allows drivers to be allocated to specific units that report to this website. The default setting is drivers are allocated to all units. Drivers can be unallocated or allocated to specific units that report to this website.

Time of Day Access Accessed by clicking “Configure Drivers”, used to set during what periods of time a specific key/code associated with a driver can take fuel. Use the Edit Time of Day List button to edit existing time of day configurations or add new ones.

Fill Limits Accessed by clicking “Configure Drivers”, sets a fill fuel limit for a specific key/code associated with a driver. This prohibits more than the specified quantity of fuel being dispensed into a given vehicle or piece of plant by the driver on a given transaction. To change the limit click in the “Allocation per Fill” field and either enter the value or over type an existing value.

Fuel Allocation Accessed by clicking “Configure Drivers”, sets a total daily allocation of fuel for a specific key/code associated with a driver. If this feature is used, the daily limit must be more than the fill limit or the vehicle will be unable to be filled to the specified limit. The two settings interact and the lower of the two will determine how much fuel can be taken.

Transaction Inputs Accessed by clicking “Configure Drivers”, use this to select what inputs are requested on a per driver basis. The options are:

1. Second ID - Can be a key or code that the driver must use in addition to his primary key or code to get fuel.
2. Enable Job Input - driver must enter a job number when refuelling the vehicle or piece of plant associated with the key or code.
3. Enable User Data Input - driver must enter User Data when refuelling the vehicle or piece of plant associated with the key or code.
4. Supervisor - when a selected driver is designated a supervisor, this means he can issue fuel to a vehicle or piece of plant without needing to enter a vehicle/plant key or code. A user can be a driver and a supervisor. If a vehicle key or code is entered before the driver ID, the user is treated as a driver. If no vehicle identification (key or code) is used to start a transaction and only a driver ID is entered/presented, the user is treated as a supervisor, if the supervisor check box has been selected.

Supervisor Inputs Accessed by clicking “Configure Drivers”, use this page to select what inputs a driver who is designated to be a supervisor must enter when they are operating as a supervisor. The options are:

1. Enable Job Entry - requires the supervisors to enter a valid job number.
2. Enable User Defined Entry - requires the supervisors to enter a valid user defined value, such as location.

Import/Export Drivers

Import or Export .csv files pre-filled with driver’s details. This is useful for batch importing a large number of drivers to the SmartFill system.

3.0.9 Tanks

Use this page to add tanks, if your SmartFill GEN 3 system has a SmartDip or Automatic Tank Gauging(ATG) interface fitted. If your SmartFill GEN 3 does not have a SmartDip or ATG interface, you can create virtual tanks called Smart Tanks, these allow you to track your tanks with manual dips, transactions that occur will automatically be subtracted from the tank volume so you can monitor your tanks in real-time. The SmartTanks feature requires a subscription to our PRO Reports website add-on.

3.0.9.1 Tanks Page

This is the Tanks page and allows you to view in almost real time, the levels in your tanks. This page shows a combination of tanks with Automatic Tank Gauging (ATG) and Smart Tanks.

The graphics displayed at the top of the page give you a visual indication of the status of your tanks, these graphics are available with PRO reports.

The table at the bottom of the tanks page lists all your tanks and the current status including the capacity of the tank, safe fill limit, current volume, last dip, and the tank name.

The colors indicate the type of tank and status of the tank. A tank with a SmartDip or ATG will be listed in the table as a white row. A Smart Tank will be listed as a green row if it has had a recent DIP, or as orange if a DIP is required



Figure 3.11: Tanks Page

From the tanks page you may edit the description of the tank by clicking into the description cell and editing the value. If you are using PRO Reports, the tank description will show as the tank name on all charts and graphs. You can see this in figure 3.11, the name of the tanks in the graphics is the tank description.

Add Manual Dip - Allows you to enter the date, time, volume and volumetric unit of a manual tank dip.

Add Delivery - Allows you to enter the date, time, volume and volumetric unit of a fuel delivery. You can also include supplier, reference number, and delivery price.

3.0.9.2 Tank Level - Columns

If you select columns below the Tank Level heading you will be presented with the configuration page for the live view of the tanks. This page enables you to select which columns are displayed and the order they show in. At the top of the page are the selected columns. You can change the column headings by selecting the heading name and then over typing it with the new name. Headings that are greyed out are set in one of the other configuration screens. You can select which columns are displayed by dragging and dropping those required into the top section or by clicking the + symbol. The columns are removed by dragging them into the bottom section or clicking the red X.

3.0.9.3 Tanks - Dips

Selecting Dips on the top toolbar shows a record of all the Daily dip transactions for all the tanks. An automatic dip is done for each tank at one minute after midnight or as close as practical to this time, effectively when the unit is next turned on.

NOTE: Selecting specific tanks above the graph will allow you to show or hide all tanks from the graph.. It also shows all extra dips generated every 2 hours or by fluctuations outside the P-Factor setting which can be set between 0-100, the default is 1.

3.0.9.4 Tanks - Transfers

Transfers To and Transfers From show all transfers pertaining to all listed tanks and as all transactions, may be exported for recording elsewhere.

3.0.9.5 Tanks - Deliveries

When there is a large change in volume in a short period of time detected in the tank, a delivery is taken to have occurred and recorded as a tank transaction if the auto deliveries feature is enabled for the tank. This is an automatic delivery. Delivery drivers can also enter a delivery at the unit by holding down the '0' key. This is recorded as a manual delivery.

3.0.9.6 Tanks - Fuel Suppliers

Add fuel suppliers and assign them keys to use at the unit on delivery, assign supplier numbers and designate fuel prices.

3.0.9.7 Configure Tanks

Add Smart Tanks The add Smart Tank button allows you to add a new tank if you have PRO Reports enabled on your account. You will be prompted to enter data for each of the columns that are displayed on the tanks page. Once a tank is added you can edit it from the tank page by selecting a field and over-typing the entry.

Figure 3.12: Add SmartTank Page

Combine Tanks Combine tanks by assigning SmartFill units and creating a name for your combined tank.

Pump name	Unit#	Pump#	Nozzle#	From Tank
Pump 1	Adelaide SmartFill 2585	1	1	None
Diesel HPI	Pixel	1	1	SmartFill 3284 Tank 2

Figure 3.13: Pump to Tank Mapping on the Website

Pumps After a SmartTank is created, it is important to map your pumps to the tank to ensure accurate reporting. Connecting each transaction with a tank allows for reconciliation of fuel use. Inflow meters should be configured on the Transfer Meters page.

Transfer Meters Configuration on this page requires a SmartFill Inflow module to be installed. Once installed, set up transfer meters with “To Tank” only for deliveries, or “From” and “To” tanks for transfers.

Mobile Tanks Configuring a key/code to a tank allows you to authorize the fill of a mobile tank at the SmartFill unit. The movement will be treated as a transfer between tanks instead of a transaction. If you have a SmartFill on the mobile tank, you can then see the fuel leaving the mobile tank as transactions.

Email Schedule Tank levels may be scheduled for specific times and sent to multiple email addresses to alert you of your tank levels.

Email Alerts You can configure email alerts for your tanks when they become offline or reach their high or low alarms, these can be sent to multiple email addresses by separating them with a comma or a semicolon.

Delivery Email Alerts You can configure email alerts to notify you of fuel deliveries. This will send you the date, time, quantity, supplier and price (if set).

3.0.10 Custom User Data

On the custom user data page you can define your own data that you want a driver to enter while refuelling e.g. a department or a location. The driver enters a numeric code that is mapped to a value on the website. Below is a page set up for the entry of test data. To use this function vehicle and/or drivers must have their transaction input set for a user defined field input.

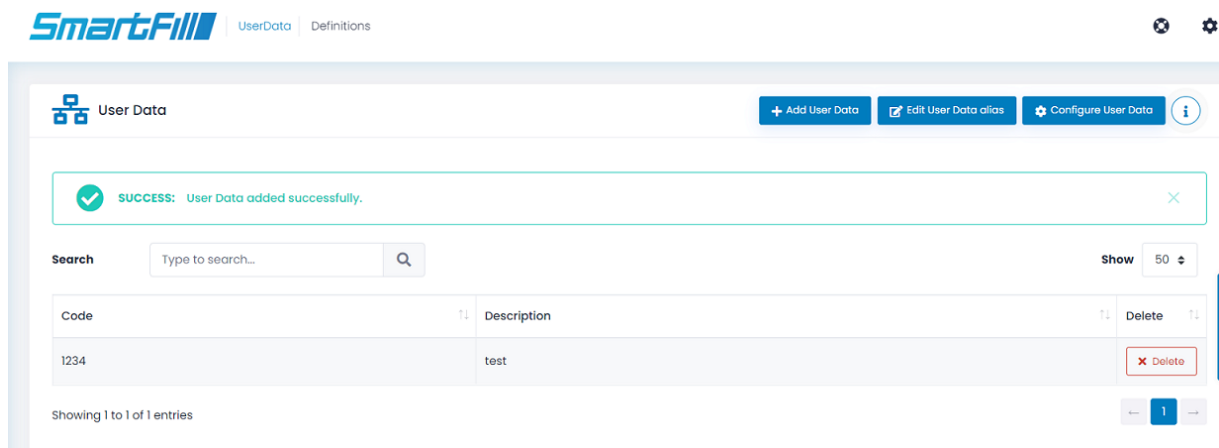

Figure 3.14: User Defined Data Page

3.0.10.1 Configure User Data

Unit Allocation Allows user defined entries to be allocated to specific units that report to this website. The default setting is they are allocated to all units. User defined data fields can be unallocated or allocated to specific units that report to this website.

3.0.11 Jobs

The details for job numbers are set up on the jobs page. On this page you can add new job numbers and map a numeric entry made at the unit to an internal job number that can be used on the transaction report.

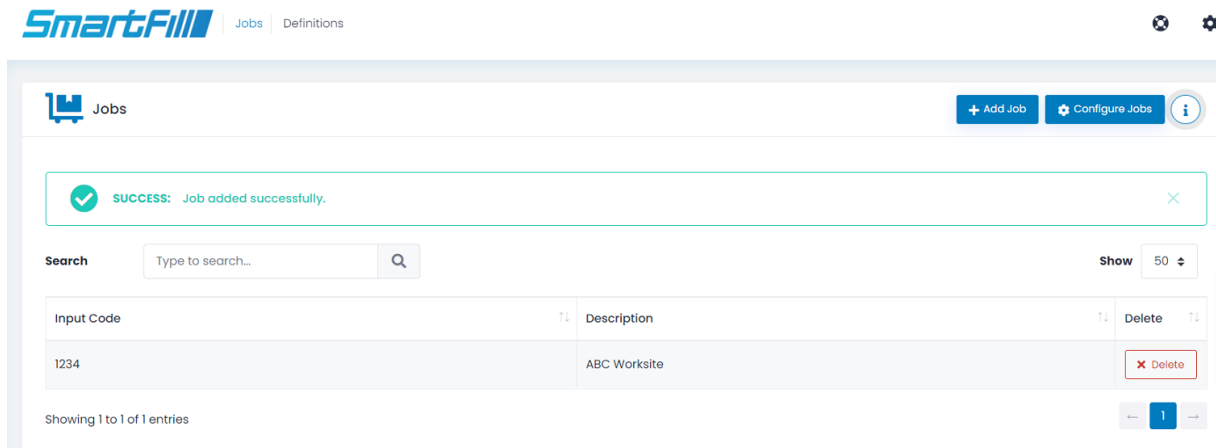

Figure 3.15: Jobs Page

3.0.11.1 Add Job

Selecting the Add button on the jobs page allows you to enter a new job number and a description for it.

3.0.11.2 Configure Jobs

Unit Allocation Allows job numbers to be allocated to specific units that report to this website. The default setting is all job numbers are allocated to all units. Job numbers can be unallocated or allocated to specific units that report to this website.

3.0.12 Units

This page enables you to see the status and the configuration of units allocated to this website and add new units.

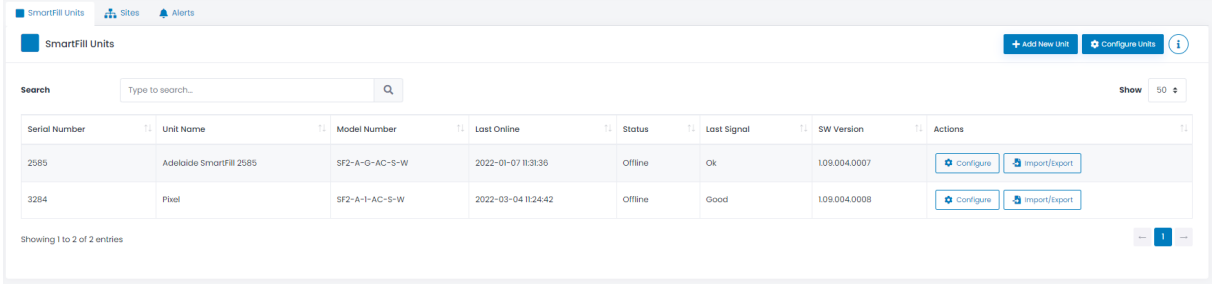

Serial Number	Unit Name	Model Number	Last Online	Status	Last Signal	SW Version	Actions
2585	Adelaide SmartFill 2585	SF2-A-G-AC-S-W	2022-01-07 11:31:36	Offline	Ok	1.09.004.0007	Configure Import/Export
3284	Pixel	SF2-A-1-AC-S-W	2022-03-04 11:24:42	Offline	Good	1.09.004.0008	Configure Import/Export

Figure 3.16: SmartFill Units Page

3.0.12.1 Alerts

Provides alerts when the SmartFill unit goes offline.

3.0.12.2 Software Update

This is where you can check and download software updates if required

3.0.12.3 Import (From Unit to Website)

If your unit(s) is not connected to the website via a network connection then transaction and configuration data will need to be transferred via a USB drive. Export data and transactions from the SmartFill GEN 3 onto a USB drive and then use the import function to import into the website. The SmartFill GEN 3 Operations manual has details on how to export data and transactions from the SmartFill GEN 3.

3.0.12.4 Export (From Website to Unit)

As above, if you have no network connection then use this function to export all the website configuration onto a USB drive so it can be imported into the SmartFill GEN 3. The SmartFill GEN 3 Operations manual has details on how to import data from a USB drive.

3.0.12.5 Add New Unit

Is used to add a new unit to this website. To do this requires the security code that is shipped with the unit.

3.0.12.6 Unit - Configure

This option is shown in the right column for each unit and is used to remotely configure options in the unit. There are four pages, if tank gauging is installed and three if there is no tank gauging.

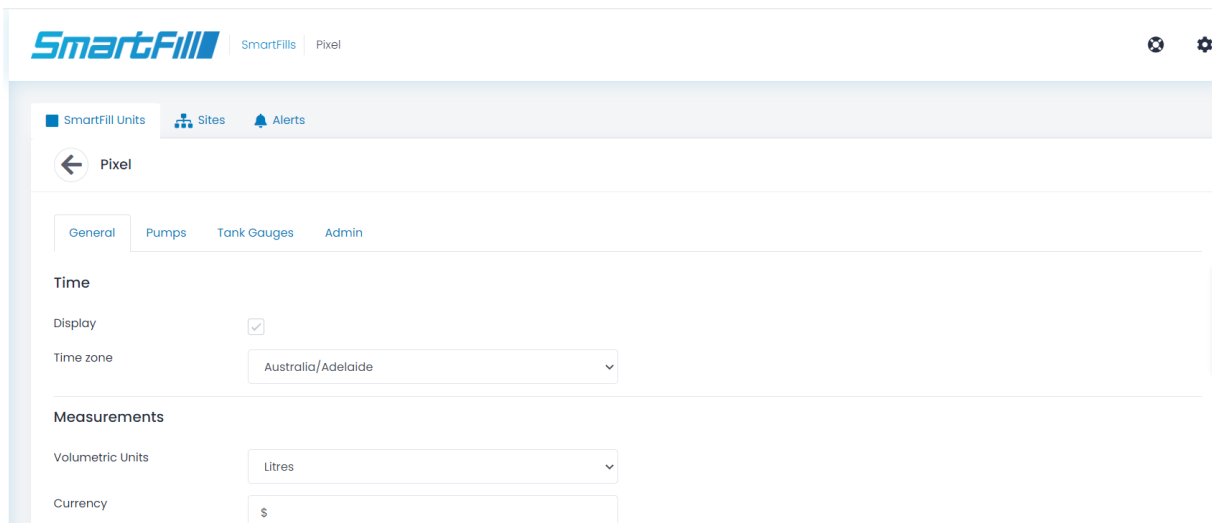

Figure 3.17: Configuration - General

1. Time

- (a) **Display** sets whether the time is shown on the display (default is on).
- (b) **Time Zone** - Select which time zone you are in.

- 2. **Measurements** - Sets what units are used for measurement in the unit. The options are liters and US or imperial gallons.
- 3. **Menu Access** - Allows you to enable the Installer Menu and change the Admin and Installer PINs.
- 4. **Security** - If the hide PIN numbers is selected, PIN entries are shown as an asterisk ' * ' on the display when the driver enters their PIN.
- 5. **Receipt Header** - Sets your Company Name as the header for any receipts.
- 6. **Other** - Sets transaction hold time and input screen timeout.

Configure - Pumps This page is used to remotely configure the pumps (hoses) in the unit.

The screenshot shows the 'SmartFill' web interface. At the top, there is a navigation bar with the 'SmartFill' logo, 'SmartFills', and 'Pixel' text. Below this is a secondary navigation bar with 'SmartFill Units', 'Sites', and 'Alerts' icons. A breadcrumb trail shows a back arrow and 'Pixel'. The main content area has four tabs: 'General', 'Pumps', 'Tank Gauges', and 'Admin'. The 'Pumps' tab is active, displaying the configuration for 'Pump 1'. The configuration fields are as follows:

Field	Value
Name	Diesel HFI
Enabled	<input checked="" type="checkbox"/>
Show Price	<input checked="" type="checkbox"/>
Bypass Detection	<input checked="" type="checkbox"/>
Fuel Type	Diesel High Flow
Fuel Price	\$ 1.750
Cutoff Freq	1
Pulser Source	1
Activation	Nozzle

Figure 3.18: Configuration - Pumps

Configure - Admin The Admin screen in the configure section is used for more advanced settings, these options are as follows:

- Protocol - Used to specify the pump protocol when using a Gilbarco pump
- Logging - This section has two options, these should only be changed if directed by support and may use additional data if enabled
 - Persistent Logs
 - Comms Debug
- Printer - Used to configure a receipt printer for use with a SmartFill unit
 - Enabled - select whether receipt printer is enabled on the unit.
 - Baud Rate - Default is 9600.
 - Data Bits - Default is 8 bits.
 - Parity - Default is none. Can be none, odd or even.
 - Stop Bits - Default is 1 bit.
- Swipe Cards
 - Enable Expiry - If using swipe cards this enables card expiry
- Offline Reboot - If the unit goes offline, this setting specifies how long before the unit should reboot to reset the connection. The unit will not reboot if a transaction is in progress.
 - Enabled - select whether to enable offline reboot.
 - Threshold - How long until the unit should reboot after going offline.
 - Interval - At which interval the unit should keep rebooting if the connection is not restored.

The screenshot shows the 'Admin' configuration page with the following settings:

Section	Setting	Value
Protocol	Protocol	2
Logging	Persistent Logs	<input type="checkbox"/>
	Comms Debug	<input type="checkbox"/>
Printer	Enabled	<input type="checkbox"/>
	Baud Rate	9600
	Data Bits	8
	Parity	None
	Stop Bits	1
Swipe Cards	Enable Expiry	<input type="checkbox"/>

Figure 3.19: Configuration - Admin

1. Used to name the pump. This name is shown on the display when the pump is in use and when the pump selection screen is show (when there is more than one hose being controlled)
2. **Enabled** - Sets whether this pump/hose is enabled on the unit. If it is not selected, the driver will not be given the option to select this pump.
3. **Show Price** - When set, will make the total price of the transaction visible on the SmartFill display.
4. **Bypass Detection** - If using a pump control module with compatible software, this feature allows you to record transactions that occurs including if an asset has not been used and the system has been bypassed.
5. **Fuel Type** - Selects the fuel type being dispensed by this pump/hose. This should ONLY be set if you are going to use fuel type checking on the vehicles or plant page.
6. **Fuel Price** - Sets the price that is displayed when the transaction is in progress. NOTE: this is a display only function and it DOES NOT enable the system to calculate the total price of delivery.
7. **Cutoff Freq** - Enables you to ignore flow rate/pulses that are very slow. Usually used when Walk time is set and there is a inflow/outflow meter used.
8. **Pulsar Source** - Enables one pulsar to be used for 2 pumps. Ex. High Flow and Low Flow Diesel using the same flow meter at a pump.
9. **Activation** - Sets the pump activation to Nozzle Switch or Walk time depending on your requirements.
10. **K-Factor** - Sets the k-factor for the pump. See ??
11. **Volume Multiplier** - Sets volume multipliers needed for accurate display of volume.
12. **Gilbarco Digits** - Sets the displayed number of digits for Gilbarco pumps. See 2.8.4
13. **Device Type** - Read-only information about the type of SmartFill Gen 3.
14. **Version** - Read-only information about the version number of the SmartFill Gen 3.
15. **Unit** - Read-only information about the unit of the SmartFill Gen 3.
16. **Slot** - Read-only information about the slot of the SmartFill Gen 3.

Tank Gauges

The screenshot shows the configuration interface for Tank Gauges. At the top, there are navigation tabs for 'General', 'Pumps', 'Tank Gauges', and 'Admin'. Below the tabs, the configuration is for 'Tank 1'. The settings are as follows:

Setting	Value
Alarm Enabled	<input type="checkbox"/>
Low Alarm Volume	0
High Alarm Volume	0
Device Type	Tank_Gauge_SmartDip
Version	1.7.0
Unit	0
Slot	1

Figure 3.20: Configuration - Tank Gauges

1. **Alarm Enabled** - sets whether the tank level alarms are active. If enabled and notifications are set on the tanks page, an SMS will be sent to the numbers on the notification list when either a low or high alarm condition occurs.
2. **Low Alarm Volume** - sets the level at which the system will send a low level alert via SMS, if configured.
3. **High Alarm Volume** - sets the level at which the system will send a high level alert via SMS, if configured.
4. **Device Type** - Shows the type of tank gauge used for each tank.
5. **Version** - Read-Only information about the version of the tank.
6. **Unit** - Read-Only information about the unit the tank is assigned.
7. **Slot** - Read-Only information about the slot that tank is assigned.

Configure - Admin The Admin screen in the configure section is used for more advanced settings, these options are as follows:

- Protocol - Used to specify the pump protocol when using a Gilbarco pump
- Logging - This section has two options, these should only be changed if directed by support and may use additional data if enabled
 - Persistent Logs
 - Comms Debug
- Printer - Used to configure a receipt printer for use with a SmartFill unit
 - Enabled - select whether receipt printer is enabled on the unit.
 - Baud Rate - Default is 9600.
 - Data Bits - Default is 8 bits.
 - Parity - Default is none. Can be none, odd or even.
 - Stop Bits - Default is 1 bit.
- Swipe Cards
 - Enable Expiry - If using swipe cards this enables card expiry
- Offline Reboot - If the unit goes offline, this setting specifies how long before the unit should reboot to reset the connection. The unit will not reboot if a transaction is in progress.
 - Enabled - select whether to enable offline reboot.
 - Threshold - How long until the unit should reboot after going offline.
 - Interval - At which interval the unit should keep rebooting if the connection is not restored.

The screenshot shows the 'Admin' configuration page with the following settings:

Section	Setting	Value
Protocol	Protocol	2
Logging	Persistent Logs	<input type="checkbox"/>
	Comms Debug	<input type="checkbox"/>
Printer	Enabled	<input type="checkbox"/>
	Baud Rate	9600
	Data Bits	8
	Parity	None
	Stop Bits	1
Swipe Cards	Enable Expiry	<input type="checkbox"/>

Figure 3.21: Configuration - Admin

3.0.13 Admin

The Admin page lists out all the users who have access to your website, from here you can manage accounts and permissions, create new accounts for your website, and change your password.

The screenshot displays the 'User Management' interface in the SmartFill Admin panel. At the top, there are navigation links for 'Users', 'Roles', and 'Settings'. Below these, the 'User Management' section includes a search bar and a 'Show 50' dropdown. The main content is a table with the following data:

Id	First Name	Last Name	Username	Account Admin	Permissions	Logged In	Last Login	Last Activity	Actions
8505	Test	McTester	@fmtweb.com	<input checked="" type="checkbox"/>	Account administrators have full access to all sites and features.	<input type="checkbox"/>	2022-01-10 09:55:19	2022-01-10 10:26:50	View Delete Re-Send Invite

At the bottom of the table, it indicates 'Showing 1 to 1 of 1 entries'.

Figure 3.22: Admin

3.0.13.1 Admin - ISO/Access Registration

This page lists the ISO/Access pairs that are authorized for use with SmartFill units registered to this website. When adding a swipe card as a vehicle/plant/driver the ISO/Access pair name must be referenced for each card so the SmartFill unit can grant authorization.

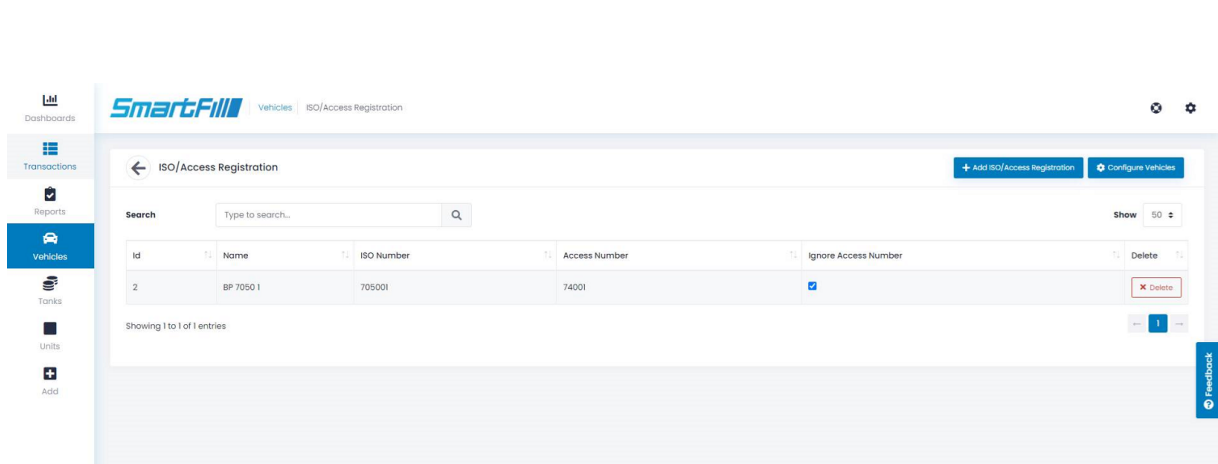

Figure 3.23: Admin ISO/Access Registration

To add an ISO/Access pair, click the **Add** button and fill out the form with the ISO and Access number and give the pair a reference name. Some cards are not encoded with an access number. For these check the "Ignore Access Number" checkbox and only include an ISO number.

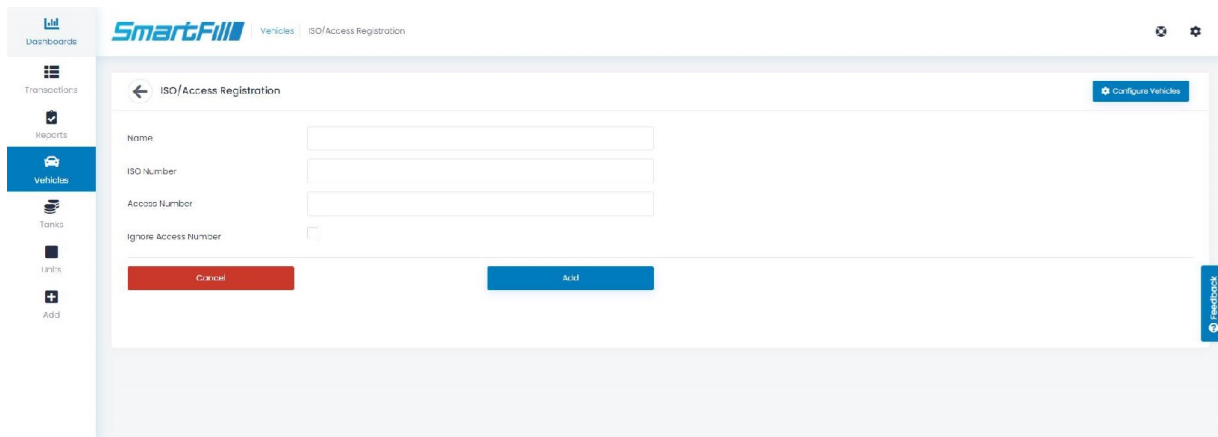

Figure 3.24: Add ISO/Access Pair

3.0.13.2 View/Edit Users

It is possible on this screen to view all users, define them as administrators or not and to delete users from the system.

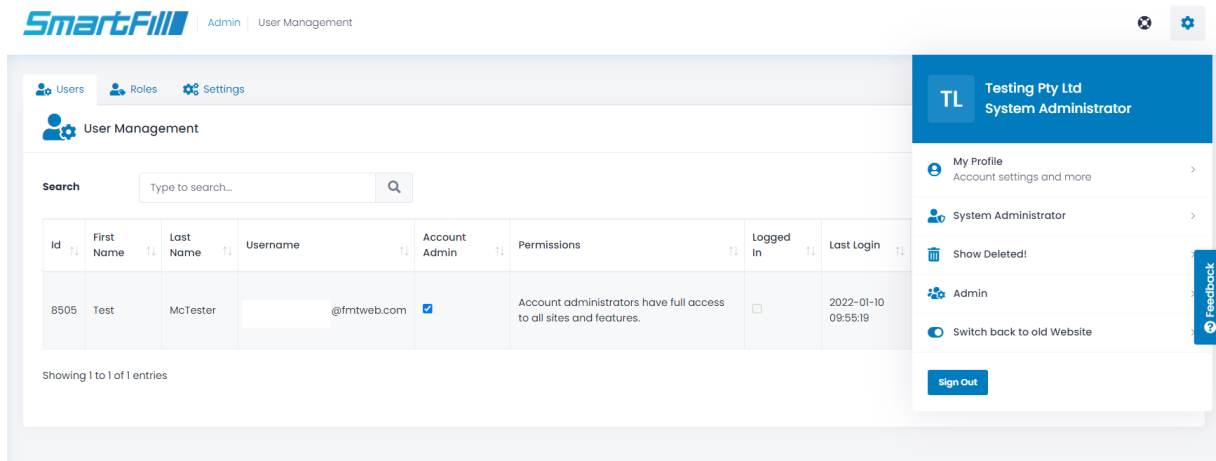

Figure 3.25: Admin View/Edit Users

3.0.13.3 Invite New User

Use this page to add new users to the system. Fill in the details and click "Invite".

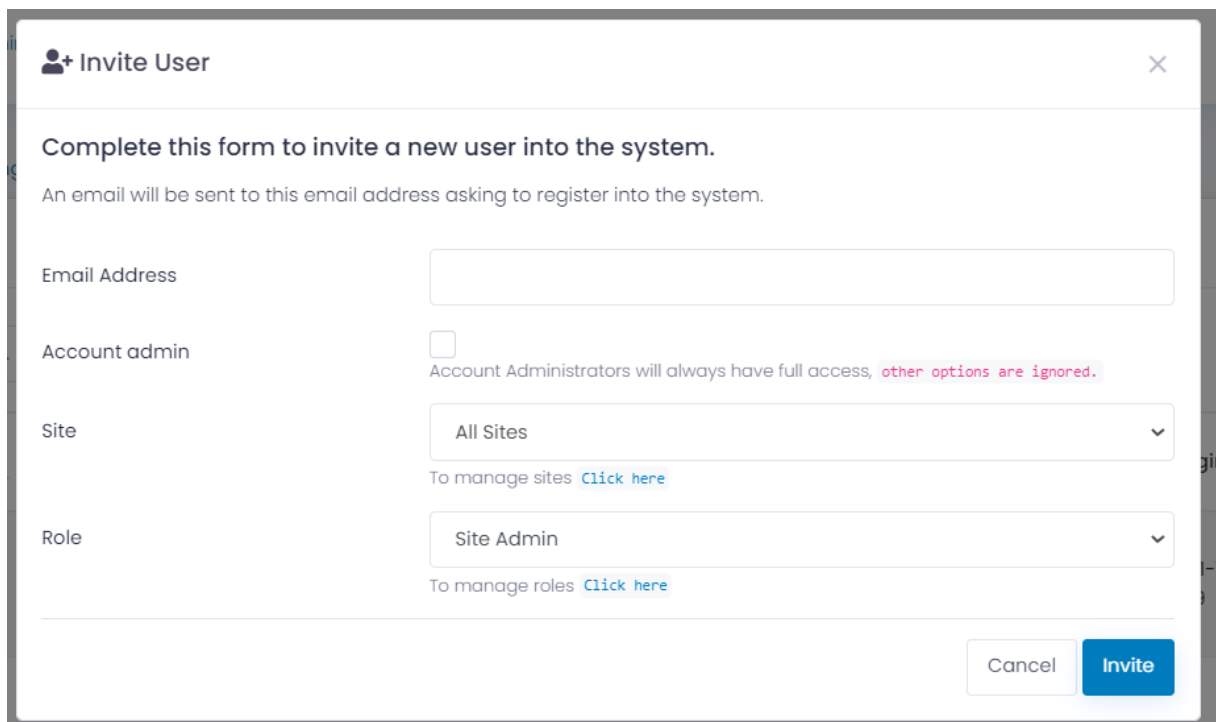

Figure 3.26: Admin Add User

3.0.13.4 My Profile - Change Password

Use this page to change the password of the currently logged in user.

The screenshot displays the 'Change Password' interface in the SmartFill Admin panel. At the top, there are navigation tabs for 'Users', 'Roles', and 'Settings'. Below these is a breadcrumb trail: 'Change Password'. The main content area is split into two columns. The left column shows the user profile for 'Test McTester', a SmartFill Expert, with contact information: Email: @fmtweb.com and Phone: 1800AMAZING. Below the profile are links for 'Personal Information', 'Profile Permissions', and 'Change Password'. The right column is the 'Change Password' form, which includes the instruction 'Update your password periodically' and three input fields: 'Current Password', 'New Password', and 'Retype New Password'. A green 'Submit' button is located at the bottom right of the form.

Figure 3.27: Admin Change Password

Chapter 4

Automatic Tank Gauging Interface

4.1 Introduction

The SmartFill fuel management system can interface with automatic tank gauging (ATG) system which supports either Veeder Root TLS 350 or 450 protocols. The interface is made via a serial port. This interface supports up to four tanks. The SmartFill fuel management system collects the following data from ATG equipment:

- 12:01 AM dip
- Continuous tank inventory level
- Fuel delivery information

Utilizing the automatic tank gauging system allows the SmartFill fuel management system to seamlessly monitor your fuel system from end to end and provide reconciliation reports on demand, at the touch of a button, or at predetermined intervals via email or SMS.

4.2 Operation

The ATG module functions by querying the tank gauging system for current inventory data. The data is imported into the SmartFill system and is accessed locally at the SmartFill console or online at the users SmartFill website.

4.3 ATG Setup

The ATG system dictates which communications protocols (RS 485 or RS 232) are to be utilized. Following the ATG manufacturer's instruction:

- Enable a communication port
- Select Veeder Root language
- Select communication standard (RS232 or RS485)

4.3.1 RS232 Serial Communication – RS232 requires a three (3) wire interface. The three (3) wires are Receive, Transmit, Common/Ground. Interconnect the two systems in accordance with Table 4.1 and Figure 4.1.

Wire	From ATG Function	Wire Color	To SmartFill Function
1	Transmit		Receive
2	Receive		Transmit
3	Common/Ground		Common/Ground

Table 4.1: RS232 Wiring

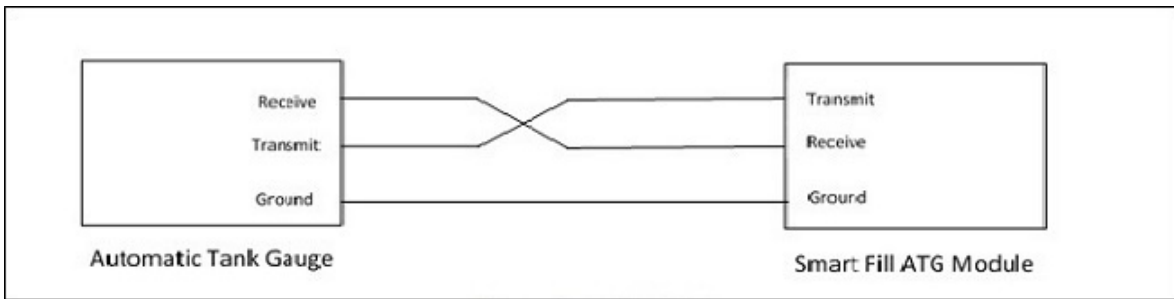

Note: the Receive and transmit wires are crossed over.

Figure 4.1: RS232 Wiring

Record the ATG RS232 communications properties in Table 4.2.

Name	Setting.
Baud Rate	
Data Bits	
Stop Bits	
Parity	

Table 4.2: RS232

4.3.2 RS485 Serial Communication – RS485 requires a two (2) wire interface. The two (2) wires are Plus and Minus. Interconnect the two systems in accordance with Table 4.3 and Figure 4.2

Wire	From ATG	Wire Color	To SmartFill
1	Plus		Plus
2	Minus		Minus

Table 4.3: RS485 Wiring

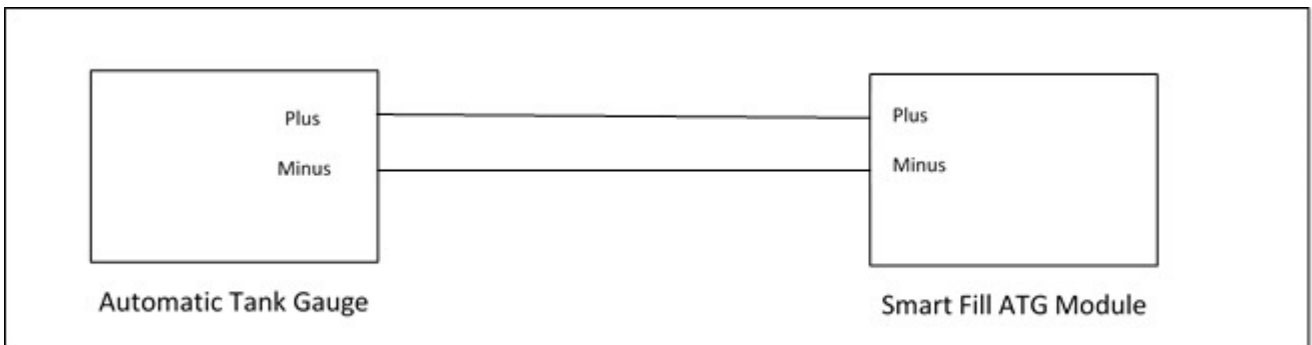

Figure 4.2: RS485 Wiring

Record the ATG RS485 communications properties in Table 4.4.

Name	Setting.
Baud Rate	
Data Bits	
Stop Bits	
Parity	

Table 4.4: RS485

4.4 SmartFill ATG module to Pneumercator TMS Series panels via RS 232

X:/Ian Working/SMARTFILL ATG INTERFACE to PNEUMERCATOR TMS SERIES CONSOLES.pdf

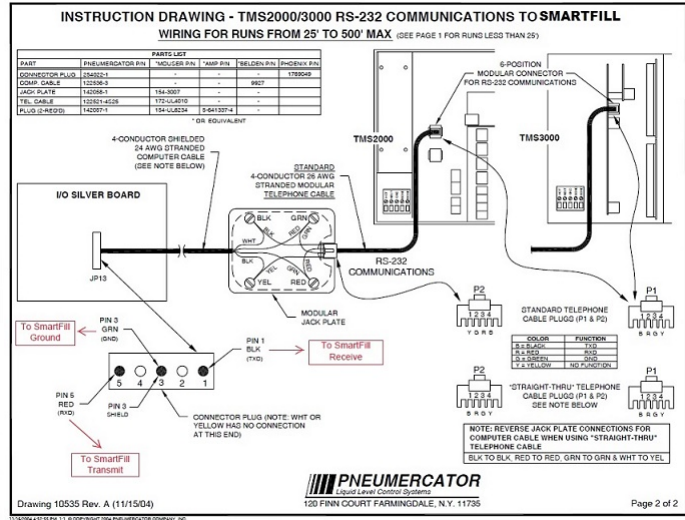
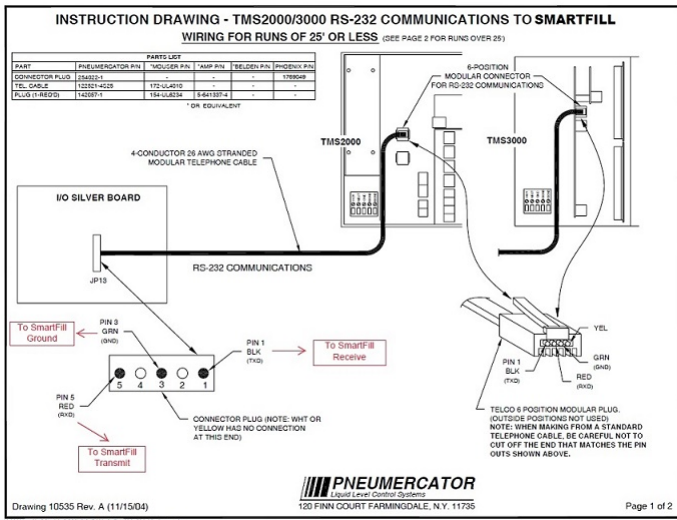

4.5 SmartFill Set Up

Module - To access an Automatic Tank Gauge, a SmartFill ATG module must be installed. To install the module, snap it into an open slot and secure it with a minimum of two (2) screws. The head of the terminal block is removable for easier wiring termination.

Serial Communication Properties –

1. Press and hold CLR and ENT to access the Admin Installer screen
2. Press 6 - 7- 8 - 9 for the default PIN then press ENT
3. Press <7> for Tanks
4. Press <4> for Comms
5. Press <1> for Baud Rate and enter the baud rate recorded in either Table 4.2 or 4.4
6. Press ENT
7. Press <2> Data Bits and enter the data bits recorded in either Table 4.2 or 4.4
8. Press ENT
9. Press <3> for Parity and enter the Parity recorded in either Table 4.2 or 4.4
10. Press ENT
11. Press <4> for Stop Bits and enter the stop bits recorded in either Table 4.2 or 4.4
12. Press ENT
13. Press <5> for Interface and select either RS232 or RS485 to match the TLS settings
14. Press ENT
15. Press CLR 3 times to return to the main screen. Note that the system announces Saving Settings

Interconnect Wiring –

Connect the TLS to the ATG module using the information recorded in the table that relates with the communications protocol you are using.

Enable Tanks –

Press and hold CLR and ENT to access the Admin Installer screen

1. Press 6 - 7- 8 - 9 for the default PIN then press ENT
2. Press <7> Tanks
3. Press <1> Tanks
4. Press <1> Tank 1
5. Press <1> Enable Tank
6. Select Yes
7. Press ENT
8. Press CLR
9. Enable up to seven (7) additional tanks by following steps 4 through 8 except select the next tank number to be enabled.
10. Press CLR until you are returned to the Main Screen to save your settings

FUNCTIONAL CHECK

Press and hold CLR until the Tank Level Screen pops up. The enabled tanks and the levels will show on the screen. It may take a minute or two for the tank levels to update and show on the screen.

Chapter 5

SmartDip Installation and Configuration

5.1 Overview

The SmartDip is a tank gauging product that is either fitted as an option to the SmartFill GEN 3 unit or supplied as a stand alone unit. One SmartDip module can monitor up to four tanks, 2 SmartDip modules can be used to monitor a maximum of 8 tanks (second module is insert into Pump slot 4). The levels from tanks can be displayed locally by holding down the CLR key if incorporated with a SmartFill GEN 3, sent via an SMS message, if a 3G/4G module is fitted and viewed on the website.

The SmartDip can generate high and low level alarms. On activation of the alarm a SMS will be sent to all numbers recorded in the unit and alarm status will be displayed on the website.

5.2 Installation

WARNING



The SmartDip has a built in Intrinsically Safe Barrier making it suitable for use with combustible liquids, such as diesel or oil and for use with flammable liquids such as motor spirit/gasoline. In the USA if the conduit for the SmartDip passes from a tank through a Class I area around a gasoline dispenser, then the installation must comply with the sealing and wiring method requirements of (NEC) Art. 501

5.2.1 Tank sensor installation to tank.

The sensor for each tank should be installed as per the diagram in figure 5.1. It is important that the probe is connected into a vented Electrical junction box

Smart-Dip Sensor Installation Into Tank.

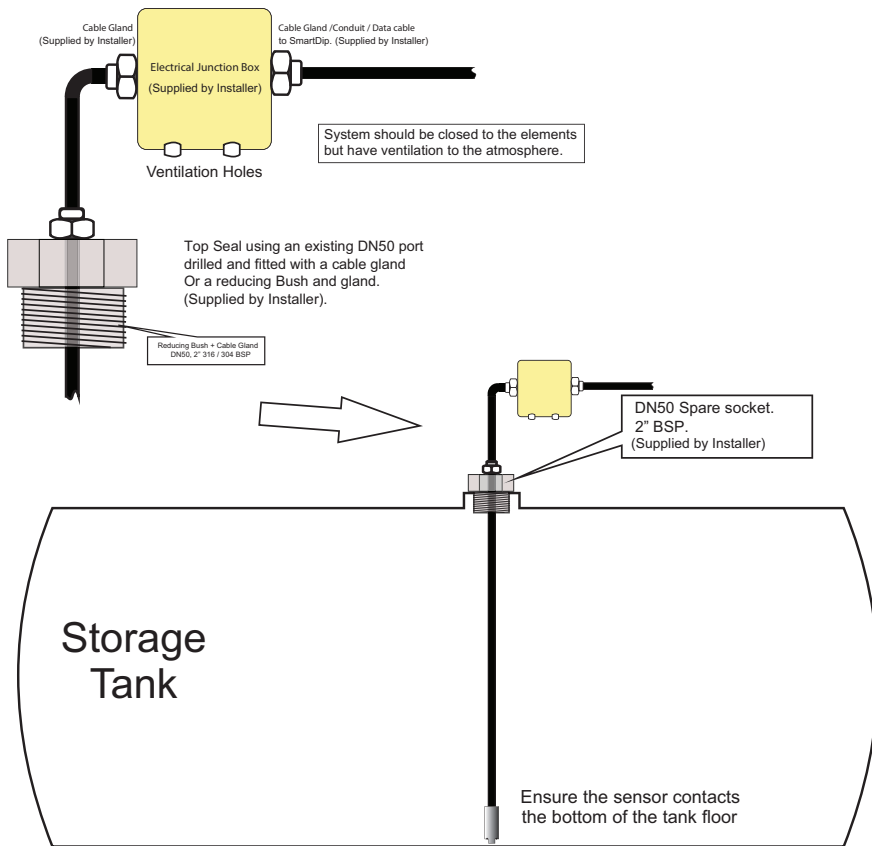

Figure 5.1: New Tank Pressure Sensor Installation

5.2.2 Tank sensor electrical connections.

This diagram shows pressure sensor connections.

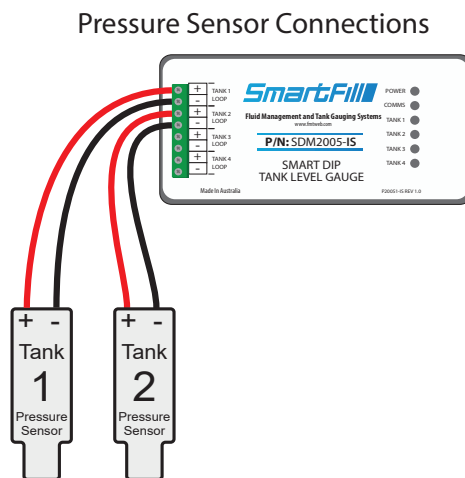

Figure 5.2: Tank Pressure Sensor Connections

NOTE: On newer SmartDip sensors Red is positive and Yellow is negative.

5.3 Set Up of SmartDip

Enter the set up mode by holding down the CLR and ENT keys and entering the required passcode. The default code is **6789**. Once the installation menu is shown press the '7' key (Tanks) to display the tank configuration menu options.

5.3.1 Tanks

If the SmartDip module is fitted the menu shown below will be shown: Select 7 to access the menus for tank gauging.



Figure 5.3: Installer menu with SmartDip fitted

5.3.2 Tank Gauging Settings

When Tank Setup is selected there are three menu options.

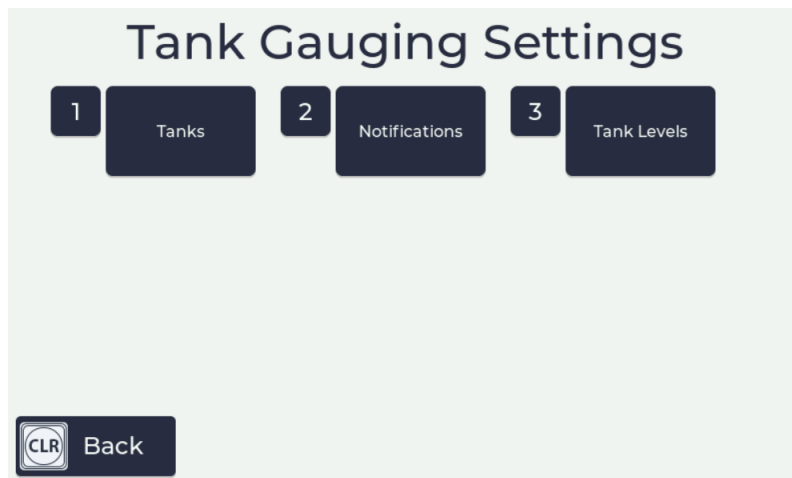

Figure 5.4: Tank Gauging Settings Menu

5.3.2.1 Tank Configuration

When the tanks menu is selected the Tanks Configuration menu will be displayed. Each SmartDip module can do tank gauging for up to four tanks and there is the possibility to have two SmartDip modules attached to each SmartFill depending upon the other configuration.

This menu is used to select what tank is to be configured. Selecting a number displays the tank configuration options for that tank.

5.3.2.2 Tank 1...8 Configuration



Figure 5.5: Tank x Configuration Menu

1. Enable Tank

- **No** - tank gauging is not enabled for this tank
- **Yes** - tank gauging is enabled for this tank

2. Type Used to select the tank type or how the tank data will be entered:

- **Rect** - tank is rectangular in shape
- **H Cyl** - tank is a horizontal cylinder
- **V Cyl** - tank is a vertical cylinder
- **20 -pt** - tank parameters will be entered using 20 data points obtained from the dipstick
- **Gauge** - You are using a third party probe or sensor that outputs a 4 - 20mA signal proportional to the tank's volume . If this option is selected you will need to enter the volumes at 4 and 20mA. Menus such as dimensions, density and sensor range will be disabled if this option is selected.

3. Dimensions This menu is used for entering the internal tank dimensions in mm for the chosen tank. The requested inputs vary depending on the tank type selected. If the 20 point option has been chosen, you will be requested for the tank height, the capacity of the tank and the volume at 20 calculated heights.

4. Density Used to enter the density of the fluid being measured. Diesel density is typically 840.

5. Sensor Range Enter the sensor range in mbar. Default value is 250 which is the correct size for all tanks up to 3 metres in height. Other values are:

- 350 for tanks up to 4 metres in height
- 450 for tanks up to 5 metres in height

The mbar value for the sensor is printed on the side of the sensor.

6. Sensor Offset Once the tank dimensions or 20 point dip data have been entered use this menu to set the sensor offset for the selected tank. Measure the volume in the tank using a dipstick and then enter in this volume into this menu using the keypad. This will calculate the sensor offset for the given volume at the dimensions previously entered.

7. Enable Alarms Enables the operation of high and low level alarms

- **No** - Alarms are not enabled
- **Yes** - Alarms are enabled

8. Low Alarm Sets the point in liters or gallons at which the low level alarm will start. On the activation of the alarm, a SMS is sent to all numbers stored in the system and an alarm status is shown on the website.

9. High Alarm Sets the point in liters or gallons at which the high level alarm will start. On the activation of the alarm, a SMS is sent to all numbers stored in the system and an alarm status is shown on the website.

5.3.2.3 Notifications

There are two options in this menu :

1. **Time** - up to six different times a day may be set for the system to send through the tank levels to the numbers entered in the next menu.
2. **SMS** - up to six numbers may be entered that will be sent the tank levels at the times specified previously or the alarms as they occur.

5.3.2.4 Tank Levels

Displays the levels for the currently enabled tanks.

5.4 Troubleshooting

5.4.1 Tank level not changing on the website

This means an interruption in the communications. Check that the SmartFill GEN 3 unit itself is connected to the website by pressing the <4> key to show the network status or by checking the SmartFill Units page of the website. Also, check the wiring from the sensor to the SmartDip module. If this has been disconnected then the website will show the last value received.

5.4.2 Tank level incorrect

Check the configuration settings for the tank at the SmartFill GEN 3 unit. See the installation manual for how to do this. If the problem persists speak to your SmartDip installer for them to check the sensor installation. The sensor must be fully sealed as fluid in contact with the sensor will degrade the reading.

5.4.3 No tank level showing

Ensure the configuration settings for the tank at the SmartFill GEN 3 unit have it set to "Enable" for that tank. If this is correct then check the wiring from the sensor to the SmartDip module as 0% means that the SmartDip module is not receiving a signal from the sensor.

5.4.4 Tank level at 100%

There is either water/fluid in the pipe that houses the sensor or there is a short in the wiring from the sensor to the SmartDip module. If the pipe has been flooded then a new sensor will be required.

5.4.5 The SmartDip module

For each tank connected to the SmartDip module there should be a LED on next to that tank designation on the module. If it is not on or flashing then that would indicate an issue with the gauging. Please contact FMT support to identify the issue.

The following fault conditions can occur on the Module:

5.4.5.1 Open Circuit

The level bar goes red and the below it the word "offline" shows. The related tank LED on the module will also not be lit

5.4.5.2 Short Circuit (current > 27.6mA)

The bar remains white with no level showing. All the tank LEDs on the module flash on and off at a 1Hz rate. Once the short is removed, the unit must be rebooted to clear the fault condition.

5.4.5.3 For testing the module there should be a 1K resistor fitted to input 4.

if you follow the steps in section 5.3 to enable Tank 4

then select H.Cyl for the Tank Type

Under Dimensions enter a Diameter of 3000 and a Length of 3000 press enter then press CLR until settings are saved.

then when you hold CLR you should see Tank 4 with about a 50% level showing, that will confirm that the Module is working.

Chapter 6

Troubleshooting at the SmartFill GEN 3 unit.

6.0.1 Key Problems

6.0.1.1 Require more vehicle keys?

- You can order new SmartFill GEN 3 keys from your SmartFill GEN 3 supplier.

WARNING

-  Always use genuine SmartFill GEN 3 keys, as there are several types of button and fob, and some types do not operate correctly with SmartFill GEN 3 system due to differences inside the button.

WARNING

-  Check that your supplier can guarantee that the keys will be SmartFill GEN 3 compatible before purchasing.

6.0.1.2 SmartFill GEN 3 does nothing when a key is presented.

1. Ensure the SmartFill GEN 3 is powered on.
2. Check the area around the sensors for dirt or moisture, and clean with a soft cloth if necessary.
3. Perform a power reset by turning the power OFF to the SmartFill GEN 3 for 30 seconds, then on again.
4. Try a different key, if it works, then the ibutton may be faulty.
5. If a different key also does not work, have an electrician check the SmartFill GEN 3 is properly powered.
6. If the key has not been supplied by the SmartFill GEN 3 manufacturers, it may not be compatible.
7. If all above are OK, ask a SmartFill GEN 3 supplier to inspect / service your SmartFill GEN 3.

6.0.1.3 Keys shows as 'INVALID'.

- The key may not have been loaded into the SmartFill GEN 3, or may be an incompatible type key (not a genuine manufacturer supplied SmartFill GEN 3 key). You can add via the installation menu at the unit or by adding them at the website.
- If the front of the SmartFill GEN 3 is wet, you may need to dry the area around the key sensors with a tissue or clean rag. Moisture around the sensors will cause the keys to misread.
- If the key has been loaded onto the website, the unit may not have synced with the website or you have not entered the key number correctly on the website

6.0.1.4 Lost vehicle keys.

If you lose a vehicle key. . .

1. Delete the key at the website or disable it at the website by deselecting enable, if you think the key is likely to be returned.

If you find old keys, you can use them again. Test them on the SmartFill GEN 3 when finding them to ensure they work, but will not operate the system. If they do operate, delete that number in the system.

6.0.1.5 Lost door lock key.

If you lose your SmartFill GEN 3 door lock key, you should replace the lock immediately. Some SmartFill GEN 3 systems have a bypass switch fitted internally, and having the door key may give the person the opportunity to bypass the SmartFill GEN 3, taking fuel unauthorized, and unrecorded.

6.0.2 Not asking for additional data?

- Check that the vehicle/driver has the correct boxes checked for additional data on the website.

6.0.3 Pump / dispenser problems.

6.0.3.1 Pump stops after a short period.

The cause of this problem is easier to identify, if you check that the Liters taken were recorded or not.

1. If Liters are NOT recorded by the SmartFill GEN 3...
 - (a) The SmartFill GEN 3 is most likely not receiving pulses from the flow meter.
2. If Liters ARE recorded by the SmartFill GEN 3.
 - (a) The SmartFill GEN 3 thinks that the nozzle has been hung up. Check wiring / micros switches etc.
 - (b) The wiring to the pump / valve may be faulty / poor connections. Check all wiring.

6.0.3.2 SmartFill GEN 3 is not recording Liters accurately.

1. Systems with relay pump modules (pulse input and relay / valve control).
 - (a) SmartFill GEN 3 is not calibrated correctly to flow meter / dispenser. The SmartFill GEN 3 should be calibrated with a proving measure or master flow meter.
2. Systems with a Gilbarco comms module
 - (a) Gilbarco communications systems. . .
 - i. The SmartFill GEN 3 and the dispenser MUST be in the same 5 or 6 digit mode. If they are set differently, the Decimal point in the Liters reading may be in the wrong place. See the relevant installers documentation for 5/6 digit setup procedures.
 - ii. The Dispenser may be set in 5 digit mode, but still allowing a fuel delivery over 999.99 Liters. This has occurred previously on PEC dispensers, and it causes the dispenser to lose the 1000's in the Liters, i.e. a delivery of 1354.77 Liters is recorded as 354.77. This is a dispenser issue, not a SmartFill GEN 3 issue. Ensure that the SmartFill GEN 3 and the dispenser are set in 6 digit mode wherever possible.

Appendix A

SmartFill GEN 3 Terminology.

ATG. Automatic Tank Gauging

Bowser. A very old brand of fuel dispenser, which has now become a loose term to describe a fuel pump / dispenser.

Comms. Communication between 2 devices, such as SmartFill GEN 3 and dispenser, or SmartFill GEN 3 and PC.

Download. The process of transferring fuel transaction data from the SmartFill GEN 3 to a USB so it can be uploaded to the website

Driver ID number. The number which identifies each driver loaded into the SmartFill GEN 3.

iButton. The small buttons which look like a watch battery. They can be used to identify each vehicle or driver. They may be mounted either in a key fob for attaching to a key ring etc, or they can be mounted directly onto your vehicle (when a reader wand is used).

LCD. The liquid crystal display panel which you view on the SmartFill GEN 3 front door.

PIN number. The unique identification number (a number from 0000 to 65000) which is used to identify each driver. PIN numbers can be linked to drivers, or to keys with each SmartFill GEN 3, and it should be guarded carefully.

PRO Reports. An add-on for the SmartFill website that provides a range of reports, charts, and other features such as SmartTanks.

Pulser. A device fitted to your fuel flowmeter or bowser, which provides electrical pulses to the SmartFill GEN 3 electronics, which it then changes to a volume of Liters.

SmartDip. A Tank Gauging system designed to incorporate directly with a SmartFill GEN 3 system, or as a stand alone system.

SmartTag/AVID. An Automatic Vehicle Identification product that is used with SmartFill to automatically identify a vehicle when fuelling using a tag attached to the vehicle.

SmartTank. A virtual tank that can be added to your SmartFill website to track tank levels if you don't have a SmartDip or Automatic Tank Gauging system installed. This feature requires PRO Reports.

Vehicle key. a different word for the unique iButton, NFC Fob or NFC proximity card that identifies each vehicle.

Walktime. Sometimes also known as a no-flow timer. This is a feature which stops the fuel pump from running for long periods of time without fuel flow. It turns the pump off after its preset Walktime (number of seconds). This time period is adjustable by the manager.

Appendix B

Operating Principles.

B.0.1 Relay control.

In order to control access to the fuel, the SmartFill GEN 3 needs to only allow access following authorization via the vehicle ID key, and optionally, that the driver pin number is valid.

Once access is approved, the SmartFill GEN 3 operates a relay which is used to start a pump or open a valve etc.

B.0.1.1 Relay.

This type of relay has a mechanical contact, which is operated by the SmartFill GEN 3 electronics.

This is normally used to switch low current, 5, 12 or 24 volt DC loads.

WARNING



Precautions must be taken to ensure that the load does not exceed the contact rating of the SmartFill GEN 3 relay. This relay can be used to control...

- A higher capacity relay, to switch a 12 or 24v pump etc.
- A solenoid or motorized ball valve.
- The low voltage nozzle switch circuit on a fuel bowser.

B.0.2 Communication access control.

SmartFill GEN 3 systems can control bowsers which use 'Gilbarco comms or NZ Pump protocol'. In these applications, when the SmartFill GEN 3 has been authorized, it sends a command to the dispenser to start the pump.

Quantities are sent from the dispenser to the SmartFill GEN 3 via comms with pulse measurement and scaling (K-Factor) done by the dispenser .